

OPERATING AND SERVICE MANUAL

**POWER
METER
431C**

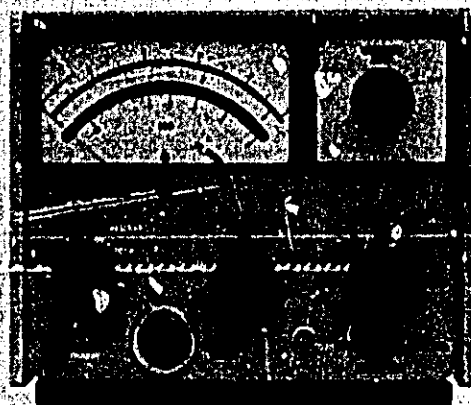

HEWLETT  PACKARD

HP 431C

POWER METER

431C

H/P Part NO. 00431-90017

SERIALS PREFIXED: 707-, 747

SERIAL PREFIXES NOT LISTED

For instruments with serials prefixed
59t, 618, 643, 648, and 651, see Manual
prefixed 648.

Copyright HEWLETT-PACKARD COMPANY 1968
1501 PAGE MILL ROAD, PALO ALTO, CALIFORNIA, U.S.A.

00431-90017 Printed: NOV 1969

HEWLETT  PACKARD

77
45-890017/545
FlO
7/24/78

TABLE OF CONTENTS

Section	Page	Section	Page
I GENERAL INFORMATION	1-1	IV PRINCIPLES OF OPERATION (Cont'd)	
1-1. Description	1-1	4-22. Feedback Current Generator	4-5
II INSTALLATION	2-1	4-24. Meter Circuit.	4-5
2-1. Initial Inspection	2-1	4-26. Metering Circuit Differential Amplifier.	4-6
2-3. Rack Mounting	2-1	4-31. DC Substitution	4-7
2-7. Primary Power Requirements	2-2	4-33. Regulated Power Supply	4-7
2-9. Three-Connector Power Cable	2-3	4-36. Power Switch.	4-8
III OPERATION	3-1	V MAINTENANCE	5-1
3-1. Introduction	3-1	5-1. Introduction	5-1
3-9. Controls, Connectors, and Indicators.	3-1	5-5. Performance Tests	5-2
3-11. Battery Operation.	3-1	5-7. Adjustments	5-2
3-16. Operation Instructions.	3-2	5-11. Cover Removal and Replacement	5-2
3-18. Major Sources of Error in Microwave Power Measurement	3-2	5-17. Power Supply Adjustment	5-4
3-31. Calibration Factor and Effective Efficiency	3-4	5-18. Oscillator Frequency Adjustment	5-4
3-44. High Accuracy of Power Measurement Using DC Substitution	3-5	5-19. Oscillator Tank Circuit Tuning.	5-4
3-53. Additional Applications	3-7	5-20. Zero and Vernier Control Adjustment	5-4
IV PRINCIPLES OF OPERATION	4-1	5-21. Coarse Null Adjustment	5-4
4-1. Overall Description	4-1	5-22. Full Scale Accuracy Adjustments	5-5
4-6. Circuit Description	4-1	5-23. Troubleshooting	5-6
4-11. Compensation and Metering Bridge Circuit	4-2	VI REPLACEABLE PARTS	6-1
4-16. Synchronous Detector	4-3	6-1. Introduction	6-1
4-20. Feedback Differential Amplifier	4-4	6-3. Ordering Information	6-1
		VII SCHEMATIC DIAGRAMS	7-1
		7-1. Introduction	7-1
		APPENDIX I - OPTION 01	A1-1
		APPENDIX I - OPTION 02	A1-1
		APPENDIX II - Long Cable Options	A2-1

LIST OF TABLES

Number	Title	Page	Number	Title	Page
1-1.	Specifications	1-1	5-7.	Meter Noise Troubleshooting	5-10
1-2.	Model 431C Thermistor Mounts	1-2	5-8.	Metering Loop Troubleshooting.	5-11
5-1.	Recommended Test Equipment	5-1	5-9.	10 kHz Oscillator Troubleshooting.	5-13
5-2.	Performance Tests	5-2	5-10.	Meter Accuracy Troubleshooting.	5-15
5-3.	Circuit Requirements for Factory Selected Parts.	5-4	5-11.	Power Supply Troubleshooting	5-16
5-4.	Front Panel Trouble Isolation	5-6	5-12.	10 kHz Amplifier Troubleshooting	5-17
5-5.	Out-of-Circuit Transistor Resistance Measurements.	5-7	6-1.	Reference Designation Index	6-2
5-6.	Safe Ohmmeter Range for Transistor Resistance Measurements	5-9	6-2.	Replaceable Parts	6-10
			6-3.	Code List of Manufacturers	6-14
			A2-1.	431C Power Meter Long Cable Options.	A2-1
			A2-2.	Conversion Kit Parts List.	A2-3

LIST OF ILLUSTRATIONS

Number	Title	Page	Number	Title	Page
1-1.	Model 431C Power Meter	1-0	4-5.	Feedback Differential Amplifier	4-5
2-1.	The Combining Case.	2-1	4-6.	Feedback Current Generator	4-5
2-2.	Steps to Place Instrument in Combining Case	2-2	4-7.	Meter Circuit	4-6
2-3.	Adapter Frame Instrument Combinations	2-2	4-8.	DC Calibration and Substitution.	4-6
2-4.	Two Half Modules in Rack Adapter	2-3	4-9.	Power Switch Arrangement	4-7
3-1.	Front and Rear Panel Controls, Connectors, and Indicators	3-0	5-1.	Cover Removal	5-3
3-2.	Mismatch Power Measurement Uncertainty	3-3	5-2.	Transistor Biasing and Operating Characteristics	5-8
3-3.	Limits of Error Before Correction	3-4	7-1.	Schematic Diagram Notes	7-1
3-4.	Total Uncertainty After Correction	3-5	7-2.	Switch Component Locations	7-2
3-5.	Output Power Leveling.	3-6	7-3.	Assembly A1 Waveforms	7-3/7-4
3-6.	Insertion Loss or Gain Measurement	3-7	7-4.	Power Meter Assembly A1.	7-3/7-4
3-7.	Control System Monitoring	3-7	7-5.	Detection and Metering Bridge with 10 kHz Oscillator Amplifier and 10 kHz Amplifier.	7-3/7-4
3-8.	Turn On and Nulling Procedure	3-8	7-6.	Power Supply Assembly A2	7-5/7-6
3-9.	DC Substitution	3-9	7-7.	Synchronous Detector, Feedback and Metering Circuits	7-5/7-6
4-1.	Block Diagram.	4-0	7-8.	Power Supply Waveform	7-7/7-8
4-2.	RF Detection Bridge.	4-2	7-9.	Power Supply.	7-7/7-8
4-3.	Compensation and Metering Bridge	4-3	A1-1.	Battery and Battery Cover Assembly	A1-1
4-4.	Synchronous Detector	4-4	A2-1.	200 Ohm Mount Calibration Circuit	A2-2
			A2-2.	100 Ohm Mount Calibration Circuit	A2-3



Figure 1-1. Model 431C Power Meter

SECTION I GENERAL INFORMATION

1-1. DESCRIPTION

1-2. The Hewlett-Packard Model 431C Power Meter, with hp temperature-compensated thermistor mounts, measures RF power from 10 microwatts (-20 dBm) to 10 milliwatts (+10 dBm) full scale in the 10-MHz to 40-GHz frequency range. Direct reading accuracy of the instrument is $\pm 1\%$ of full scale. By selector switch, the instrument normalizes the power meter reading to compensate for the Calibration Factor of a thermistor mount used for a given measurement. A rechargeable nickel-cadmium battery is included with Option 01 instruments for portable operation. Complete specifications are presented in Table 1-1.

1-3. The Model 431C makes provision for using the DC substitution method of measuring RF power and to assure accuracy of the power meter calibration. Outputs are provided for a digital voltmeter readout, permanent recording of measurements, operation of alarm

or control systems, or to allow the Power Meter to be used in a closed-loop leveling system.

1-4. **INSTRUMENT IDENTIFICATION.** The Model 431C carries an eight-digit serial number (000-00000). When the SERIALS PREFIXED number on the title page of the manual is the same as the first three digits of the instrument serial number, the manual applies directly to the instrument.

1-5. **ACCESSORIES.** Two accessories are supplied with the Model 431C Power Meter: a 7.5-foot (2290 mm) detachable power cable and a 5-foot (1520 mm) cable that connects a thermistor mount to the instrument. Thermistor mounts are available (refer to Table 1-2) but not supplied with the power meter. A rechargeable battery with installation kit is also available. Supplied and available accessories are listed in Table 1-1.

Table 1-1. Specifications

Power Range: 7 ranges with full-scale readings of 10, 30, 100, and 300 μ W, 1, 3, and 10 mW; also calibrated in dBm from -20 dBm to +10 dBm full scale in 5 dB steps.

Accuracy:

+20°C to +35°C:

- $\pm 1\%$ (100 μ W range and above)
- $\pm 1.5\%$ (30 μ W range)
- $\pm 2\%$ (10 μ W range)

0°C to +55°C:

- $\pm 3\%$ (all ranges)

Calibration Factor Control: 13 position switch normalizes meter reading to account for thermistor mount Calibration Factor (or Effective Efficiency). Range: 100% to 88% in 1% steps.

Thermistor Mount: External temperature-compensated thermistor mounts required for operation (hp 478A and 486A series listed in Table 1-2).

Meter Movement: Taut-band suspension, individually calibrated mirror-backed scales. Milliwatt scale greater than 4.25 in. (108 mm) long.

Zero Carryover: Less than 1% of full scale when zeroed on most sensitive range.

Zero Balance: Continuous control about zero point.

DVM Output: 1.000V into open circuit corresponds to full scale meter deflection (1.0 on 0-1 scale) $\pm 0.5\%$; 1 K Ω output impedance, BNC female connector; effect of loading impedance less than 10 M Ω must be accounted for.

Recorder/Leveler Output: With load impedance of 500 ohms or more, output is approximately 1 volt

dc at full scale meter deflection. BNC female connector.

DC Calibration Input: Binding posts for calibration of bridge with hp 8402B Callibrator or precise dc standards.

RFI: Meets all conditions specified in MIL-I-6181D.

Power: 115 or 230 volts $\pm 10\%$, 50 to 400 Hz, 2.5 watts. Optional rechargeable battery provides up to 24 hours continuous operation.

Dimensions: 7-25/32 in. wide, 6-3/32 in. high, 11 in. deep from front of side rail (190 x 115 x 279 mm).

Weight: Net, 7 lb (3,2 kg), 9 lb (4,1 kg) with battery.

Furnished: 5-ft (1520 mm) cable for hp temperature compensated thermistor mounts; 7.5 ft (2290 mm) power cable, NEMA plug.

Available: 00415-606 Rechargeable Battery Pack for field installation.

5060-0797 Rack Adapter Frame (holds two instruments the size of the 431C, e.g., 431C and 415E SWR Meter).

H01-8401A Leveler Amplifier.

8402B Power Meter Callibrator.

Combining Cases:

1051A, 11-1/4 in. (286 mm) deep

1052A, 16-3/8 in. (416 mm) deep

These Combining Cases accept the small hp module instrument for bench use or rack mounting.

Table 1-1. Specifications (Cont'd)

Options:	11. With 50-foot (15240 mm) cable for 100Ω mount.
01. Rechargeable battery installed, provides up to 24 hours continuous operation.	12. With 100-foot (30480 mm) cable for 100Ω mount.
02. Rear thermistor mount input connector wired in parallel with front panel input connector.	13. With 200-foot (60960 mm) cable for 100Ω mount.
09. With 10-foot (3050 mm) cable for 100Ω or 200Ω mount.	21. With 50-foot (15240 mm) cable for 200Ω mount.
10. With 20-foot (6100 mm) cable for 100Ω or 200Ω mount.	22. With 100-foot (30480 mm) cable for 200Ω mount.
	23. With 200-foot (60960 mm) cable for 200Ω mount.

Table 1-2. Model 431C Thermistor Mounts

hp Type		Frequency Range	Operating Resistance in Ohms
Coaxial	Waveguide		
8478B		10 MHz to 18 GHz	200
478A		10 MHz to 10 GHz	200
	S486A	2.6 to 3.95 GHz	100
	G486A	3.95 to 5.85 GHz	100
	J486A	5.3 to 8.2 GHz	100
	H486A	7.05 to 10.0 GHz	100
	X486A	8.2 to 12.4 GHz	100
	M486A	10.0 to 15.0 GHz	100
	P486A	12.4 to 18.0 GHz	100
	K486A	18.0 to 26.5 GHz	200
	R486A	26.5 to 40.0 GHz	200

SECTION II INSTALLATION

2-1. INITIAL INSPECTION.

2-2. Before shipment this instrument was inspected and found free of mechanical or electrical defect. As soon as the instrument is unpacked, inspect for any damage that may have occurred in transit. Check for the supplied accessories. Electrical performance may be tested using the performance test procedure outlined in Table 5-2. If there is any damage or deficiency, or if electrical performance is not within specifications, notify the carrier and your nearest Hewlett-Packard Sales and Service Office immediately.

2-3. RACK MOUNTING

2-4. The Model 431C is narrower than full-rack width. This is termed a "sub-modular" unit. When used alone, the instrument can be bench mounted. When used in combination with other sub-modular units it may be

bench or rack mounted. The hp combining case and the adapter frame are specifically for this purpose.

2-5. **COMBINING CASE.** The Model 1051A Combining Case is shown in Figures 2-1 and 2-2. This case is a full-rack width unit which accepts varying combinations of sub-modular instruments. The case itself is a full-module unit. It can be bench or rack mounted; a rack-mounting kit is supplied with the case.

2-6. **ADAPTER FRAME.** The 5060-0797 Adapter Frame is shown in Figure 2-3. The frame accepts a variety of sub-modular units in a manner suitable for rack mounting. Sub-modular units, in combination with any necessary spacers are assembled within the frame. The sub-modular units and the adapter frame, together forming a complete assembly, can then be

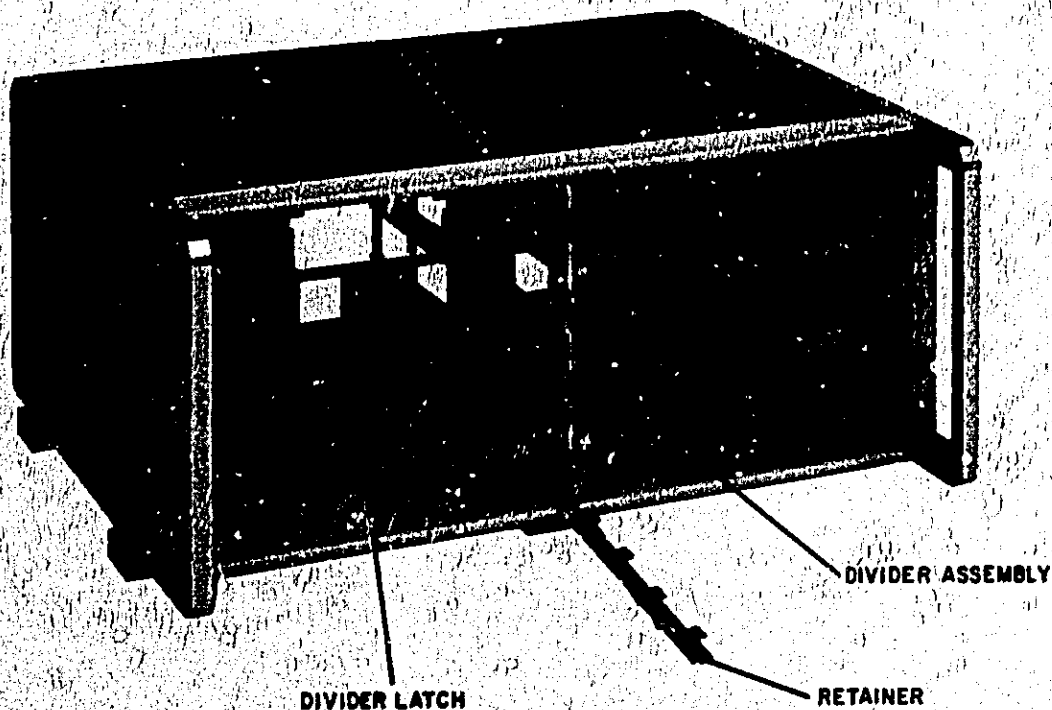
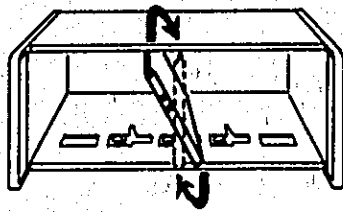

Figure 2-1. The Combining Case

Section II
Paragraphs 2-7 to 2-8

Model 431C

①
INSERT DIVIDER, ENGAGING
TABS IN TOP AND BOTTOM
MOUNTING SLOTS



②
TWIST DIVIDER TO VERTICAL
POSITION

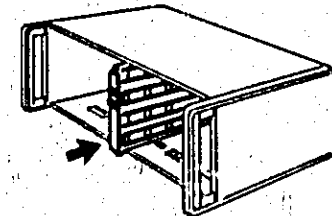

③
PUSH IN TO LIMIT

④
SLIDE LATCH TO LOCK
DIVIDER

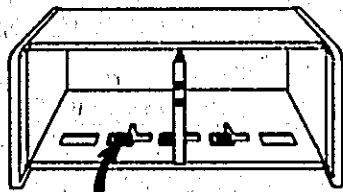

⑤
PUSH RETAINER DOWN
TO RELEASE

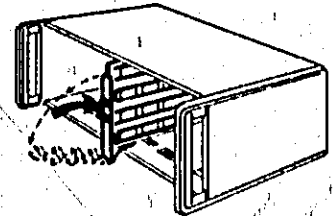

⑥
SLIDE INSTRUMENT
INTO CASE

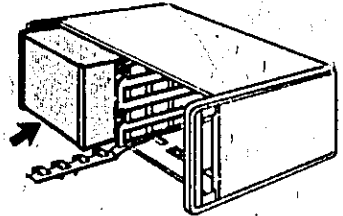

⑦
TO SET RETAINER BACK IN
PLACE, ENGAGE HOOKS FIRST
ON ONE SIDE OF DIVIDER,
THEN ON OTHER

⑧
PUSH RETAINER UP TO LOCK

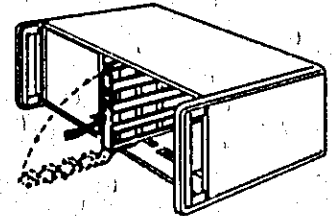

Figure 2-2. Steps to Place Instrument in Combining Case

mounted in a standard rack. The sub-modular units cannot be removed individually when the adapter frame is used. Instructions for assembly of the adapter frame and sub-modular units are given below. Refer to Figure 2-4.

- a. Place the adapter frame on the edge of a bench, step 1.
- b. Stack the sub-modular units in the frame, step 2.
- c. Place the spacer clamps between the instruments, step 3.
- d. Place the spacer clamps on the two end instruments. Push the combination into the frame, step 4.
- e. Insert screws on either side of the frame, step 5. Tighten until the sub-modular units are tight in the frame.

2-7. PRIMARY POWER REQUIREMENTS.

2-8. The Model 431C can be operated from an AC or DC primary power source. The AC source can be either 115- or 230-volt, 50 to 400 Hz. The DC source is a 24-volt rechargeable battery. The rechargeable battery is supplied with Option 01 instruments.

CAUTION

For AC operation, set the rear-panel 115-230 volt switch to the proper position before connecting the power cord to the service outlet.

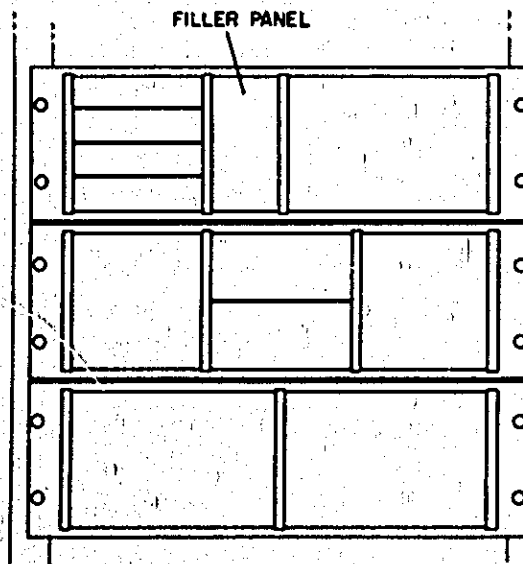

Figure 2-3. Adapter Frame Instrument Combinations

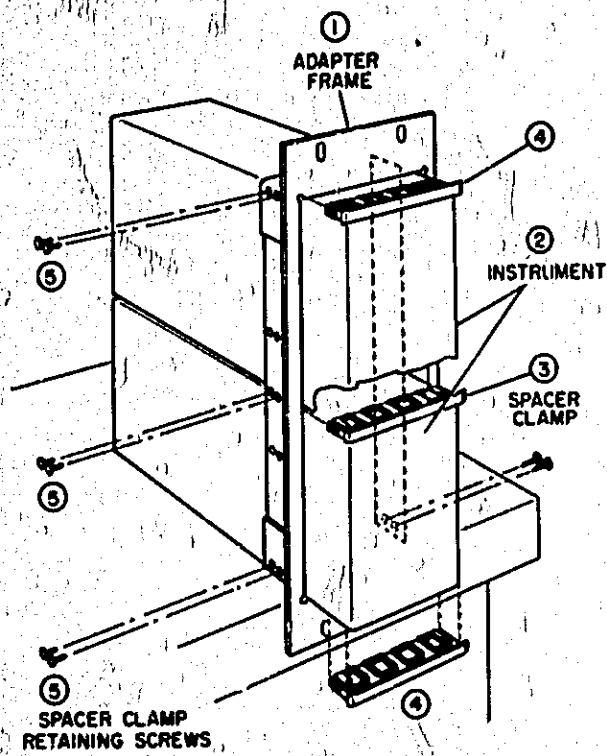
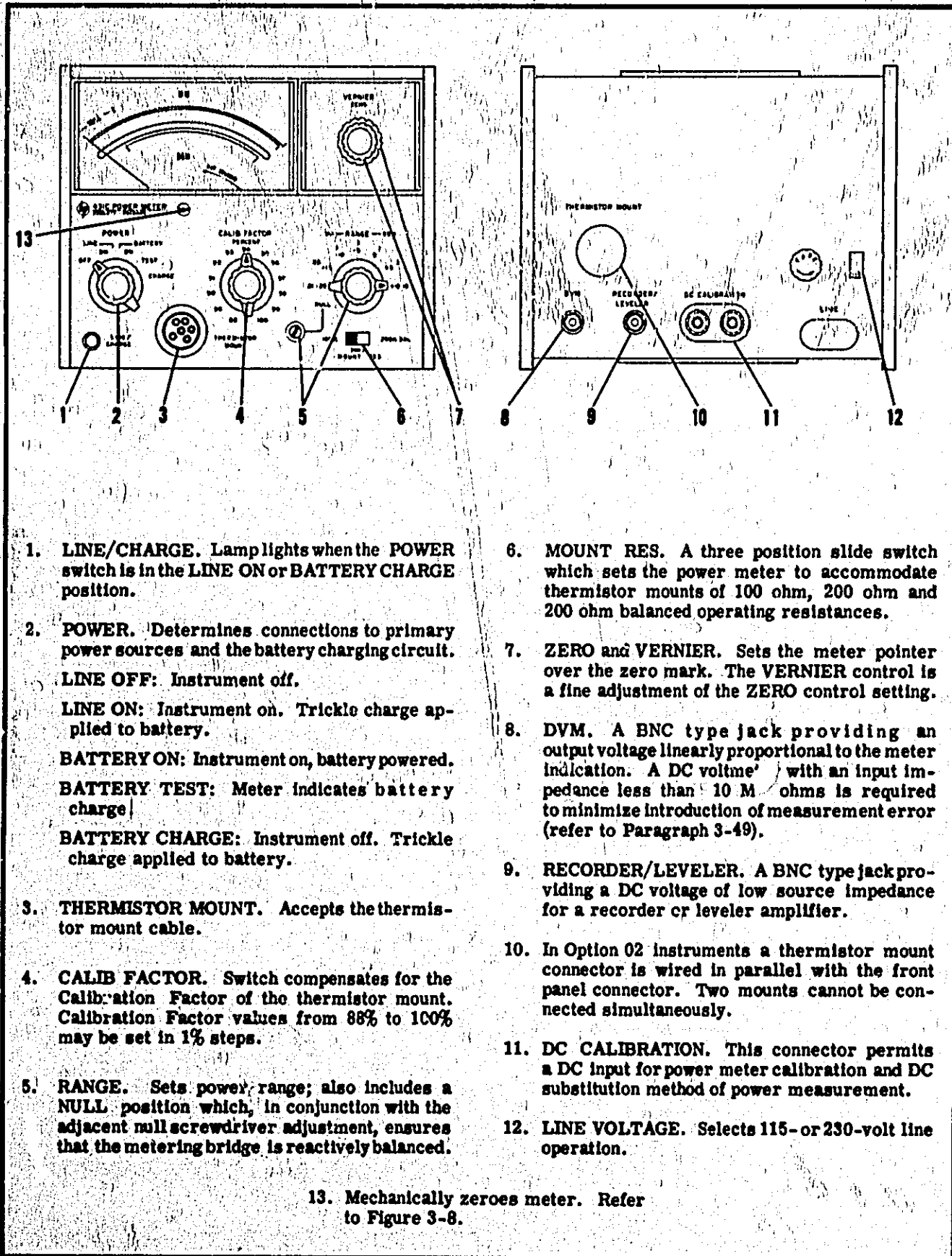

Figure 2-4. Two Half Modules in Rack Adapter

2-9. THREE-CONNECTOR POWER CABLE.

2-10. To protect operating personnel, the National Electrical Manufacturers' Association (NEMA) recommends that the instrument panel and cabinet be grounded. This instrument is equipped with a three-conductor power cable which, when plugged into an appropriate receptacle, grounds the instrument. The offset pin on the power cable three-prong connector is the ground wire. To preserve the protection feature when operating the instrument from a two-contact outlet, use a three-prong to two-prong adapter and connect the green pigtail on the adapter to ground.



1. **LINE/CHARGE.** Lamp lights when the POWER switch is in the LINE ON or BATTERY CHARGE position.
2. **POWER.** Determines connections to primary power sources and the battery charging circuit.
LINE OFF: Instrument off.
LINE ON: Instrument on. Trickle charge applied to battery.
BATTERY ON: Instrument on, battery powered.
BATTERY TEST: Meter indicates battery charge.
BATTERY CHARGE: Instrument off. Trickle charge applied to battery.
3. **THERMISTOR MOUNT.** Accepts the thermistor mount cable.
4. **CALIB FACTOR.** Switch compensates for the Calibration Factor of the thermistor mount. Calibration Factor values from 88% to 100% may be set in 1% steps.
5. **RANGE.** Sets power range; also includes a NULL position which, in conjunction with the adjacent null screwdriver adjustment, ensures that the metering bridge is reactively balanced.

6. **MOUNT RES.** A three position slide switch which sets the power meter to accommodate thermistor mounts of 100 ohm, 200 ohm and 200 ohm balanced operating resistances.
7. **ZERO and VERNIER.** Sets the meter pointer over the zero mark. The VERNIER control is a fine adjustment of the ZERO control setting.
8. **DVM.** A BNC type jack providing an output voltage linearly proportional to the meter indication. A DC voltmeter with an input impedance less than 10 M ohms is required to minimize introduction of measurement error (refer to Paragraph 3-49).
9. **RECORDER/LEVELER.** A BNC type jack providing a DC voltage of low source impedance for a recorder or leveler amplifier.
10. In Option 02 instruments a thermistor mount connector is wired in parallel with the front panel connector. Two mounts cannot be connected simultaneously.
11. **DC CALIBRATION.** This connector permits a DC input for power meter calibration and DC substitution method of power measurement.
12. **LINE VOLTAGE.** Selects 115- or 230-volt line operation.

13. Mechanically zeroes meter. Refer to Figure 3-8.

Figure 3-1. Front and Rear Panel Controls, Connectors, and Indicators

SECTION III OPERATION

3-1. INTRODUCTION.

3-2. This section presents the basic information required to operate the Model 431C Power Meter. A discussion of microwave power measurement with emphasis on modern techniques, accuracy considerations and sources of error is available in Application Note 64, available from any Hewlett-Packard Sales and Service Office.

3-3. The Model 431C is an automatic self-balancing power-measuring instrument employing dual-bridge circuits. The power meter is designed to operate with hp temperature-compensated thermistor mounts such as the 8478B and 478A Coaxial and 486A Waveguide series. Power may be measured with these mounts in 50-ohm coaxial systems from 10 MHz to 18 GHz, and in waveguide systems from 2.6 GHz to 40 GHz. Full-scale power ranges are 10 microwatts to 10 milliwatts and -20 dBm to +10 dBm. Extended measurements may be made to 1 microwatt and to -30 dBm. The total measurement capacity of the instrument is divided into seven ranges, selectable by a front panel RANGE switch.

3-4. ZERO and VERNIER zero-set controls zero the meter. Zero carry-over from the most sensitive range to the other six less sensitive ranges is accurate to $\pm 1\%$. Greater accuracy can be obtained by setting the zero point on the particular range to be used. When the RANGE switch is in the NULL position, the meter indicates inherent metering bridge unbalance, and a front panel NULL screwdriver adjustment is provided for initial calibration.

3-5. The CALIB FACTOR switch allows the introduction of discrete amounts of compensation for measurement uncertainties related to SWR, and measurement errors caused by substitution error and thermistor mount efficiency. The appropriate selection of a Calibration Factor value permits direct meter reading of the RF power delivered to an impedance equal to the characteristic impedance (Z_0) of the transmission line connecting the thermistor mount to the RF source. Calibration Factor values are determined from the data marked on the label of each 8478B, 478A, or 486A thermistor mount.

3-6. The Model 431C has a DC CALIBRATION jack on the rear panel that can be used for DC substitution method of power measurement. DC substitution is an extension of the power measurement technique normally used. Through the use of DC substitution, instrument error can be reduced from a nominal value of $\pm 1\%$ to $\pm 0.16\%$ of reading, or less, depending on the care taken in procedure and accuracy of auxiliary equipment.

3-7. The MOUNT RES switch on the front panel permits the use of three types of thermistor mounts with the 431C. Model 486A waveguide mounts can be used by setting the MOUNT RES switch to the 100 Ω or 200 Ω position, depending on the microwave band used (refer to Table 1-2). The 200 Ω position is used with Model 478A thermistor mounts and the 200 Ω BAL position is used with a balanced thermistor mount such as the 8478B.

CAUTION

To avoid severe damage to the thermistor mount, be careful not to move the MOUNT RES switch while operating the RANGE switch.

3-8. Two output BNC type jacks are provided on the rear panel of the instrument, labeled DVM and RECORDER/LEVELER. The DVM jack provides a voltage linearly proportional to the meter current; 1 volt equal to full scale meter deflection. A DVM connected to the 431C must have an input impedance greater than 500 k ohms on the range used. The RECORDER/LEVELER jack furnishes a DC voltage of low source impedance necessary for isolation between a recorder or leveler amplifier and the metering circuit of the power meter. The output voltage is proportional to the power measured and is offset ± 40 mV or less from its nominal value, depending on the load impedance. This output voltage allows the Model 431C to be used in a number of additional applications (refer to Paragraph 3-53).

3-9. CONTROLS, CONNECTORS, AND INDICATORS.

3-10. The front and rear panel controls, connectors, and indicators are explained in Figure 3-1. The descriptions are keyed to the corresponding items which are indicated on the figure. Further information regarding the various settings and uses of the controls, connectors, and indicators is included in the applicable procedures of this section.

3-11. BATTERY OPERATION.

3-12. The Model 431C option 01 can operate from battery instead of a conventional 115- or 230-volt primary power source. A rechargeable Nickel-Cadmium battery is factory installed in Option 01 instruments. The same battery can be ordered and later installed in the basic instrument, thereby modifying the power meter to the Option 01 configuration. The rechargeable battery installation kit may be ordered by hp stock number 00415-806. Option 01 installation instructions are given in Appendix I.

3-13. OPTIMUM BATTERY USAGE. It is recommended that the Model 431C be operated by the battery for up to 8 hours, followed by 16 hours of recharge. If continuous battery operation is required for more than 8 hours, the recharge time should be double the operating time. Continuous battery operation is possible for up to 24 hours but this must be followed by a prolonged recharge period.

Section III Paragraphs 3-14 to 3-25

3-14. INITIAL BATTERY USE. When the Model 431C is to be battery operated for the first time, perform the following steps:

a. Set the POWER switch to the BATTERY TEST position and note meter pointer indication. A meter pointer indication within the "BAT CHARGED" area indicates the internal battery is properly charged and ready for use. A meter pointer indication to the left of the "BAT CHARGED" area means that the battery must be charged as described below. Actual battery voltage can be measured on the 0-3 mW scale. Battery voltage is equal to 10 times meter scale reading.

b. Connect the Model 431C to AC power source. Set POWER switch to BATTERY CHARGE and charge the battery until a meter pointer indication within the "BAT CHARGED" region can be obtained as in step a.

3-15. BATTERY STORAGE. Store the battery at or below room temperature. Extended storage at high temperatures will reduce the cell charge but will not damage the battery if the temperature is below 140°F. Charge the battery after removal from storage and before using the Model 431C for battery operation.

3-16. OPERATING INSTRUCTIONS.

3-17. Figure 3-8, Turn-On and Nulling Procedure, and Figure 3-9, DC Substitution, present step-by-step instructions for operating the Model 431C. Steps are numbered to correspond with the appropriate control, connector, or indicator on the power meter and/or required auxiliary equipment.

3-18. MAJOR SOURCES OF ERROR IN MICROWAVE POWER MEASUREMENT.

3-19. A number of factors affect the overall accuracy of power measurement. Major sources of error are presented in the following paragraphs to show the cause and effect of each error. Particular corrections or special measurement techniques can be determined and applied to improve overall measurement accuracy. The following are the major sources of error to consider: 1) Mismatch error, 2) RF losses, 3) DC-to-microwave substitution error, 4) Thermoelectric effect error, and 5) Instrumentation error.

3-20. MISMATCH ERROR. The following discussion uses the terms conjugate power, Z_0 available power, conjugate match and mismatch, and Z_0 match and mismatch. These basic terms are defined as follows:

Conjugate power is the maximum available power. It is dependent on a conjugate match condition in which the impedance seen looking toward the thermistor mount is the complex conjugate of the impedance seen looking toward the RF source. A special case of this maximum power transfer is when both the RF source and the thermistor mount have the same impedance as the transmission line.

Z_0 available power is the power a source will deliver to a Z_0 load. It is dependent on a Z_0 match condition in which the impedance seen looking into a transmission line is equal to the characteristic impedance of the line.

3-21. In a practical measurement situation, both the source and thermistor mount have SWR, and the source is seldom matched to the thermistor mount without the use of a tuner. The amount of mismatch loss in any measurement depends on the total SWR present. The impedance that the source sees is determined by the actual thermistor mount impedance, the electrical length of the line, and the characteristic impedance of the line, Z_0 .

3-22. In general, neither the source nor the thermistor mount has Z_0 impedance, and the actual impedances are known only as reflection coefficients, mismatch losses or SWR. These forms of information lack phase information data. As a result, the power delivered to the thermistor mount and hence the mismatch loss can only be described as being somewhere between two limits. The uncertainty of power measurement due to mismatch loss increases with SWR. Limits of mismatch loss are generally determined by means of a chart such as the Mismatch Loss Limits charts in Application Note 64.*

3-23. An example may explain how imperfect match affects the uncertainty of power measurement. A typical Z_0 available power measurement situation can involve a source with an SWR of 1.7 ($\rho_S = 0.26$) and a thermistor mount with an SWR of 1.3 ($\rho_M = 0.13$). Figure 3-2 shows a plot of power levels and mismatch power uncertainties that result from source and thermistor mount mismatch. The source Z_0 mismatch results in a power loss of -0.29 dB from the maximum power that would be delivered by the source to a conjugate match. The power level that results from this loss is the Z_0 available power. The thermistor mount Z_0 mismatch causes an additional power loss of -0.07 dB. However, on the thermistor mount Z_0 mismatch loss is an uncertainty resulting from the unknown phase relationships between the impedances of the source and thermistor mount. This uncertainty is +0.30 dB to -0.28 dB and can be determined from the Mismatch Loss Limits charts in Application Note 64.

3-24. The result of the total mismatch loss uncertainty on the Z_0 available power level is determined by algebraically adding the thermistor mount loss to the uncertainty caused by source and thermistor mount Z_0 mismatch SWR. Thus, the Z_0 available power uncertainty is (-0.07 dB) + (+0.30 dB), and (-0.07 dB) + (-0.28 dB), equal to a range of +0.23 dB to -0.35 dB or +5.5% to -8.2%. The power delivered by the source to a Z_0 load, with source and thermistor mount mismatch as in this example, would be somewhere between 0.23 dB (5.5%) below the maximum power and 0.35 dB (8.2%) above the minimum power actually entering the thermistor mount.

3-25. Power measurement uncertainty caused by mismatch loss is one source of error to consider when measuring Z_0 available power without a tuner. A continuation of this example is given in Paragraphs 3-38 through 3-39 to discuss the basic principle of Calibration Factor correction to a measurement of Z_0 available power.

*Detailed analysis of accuracy degradation due to SWR in the transmission line is presented in Application Note 64. The Application Note may be obtained from any Hewlett-Packard Sales and Service Office.

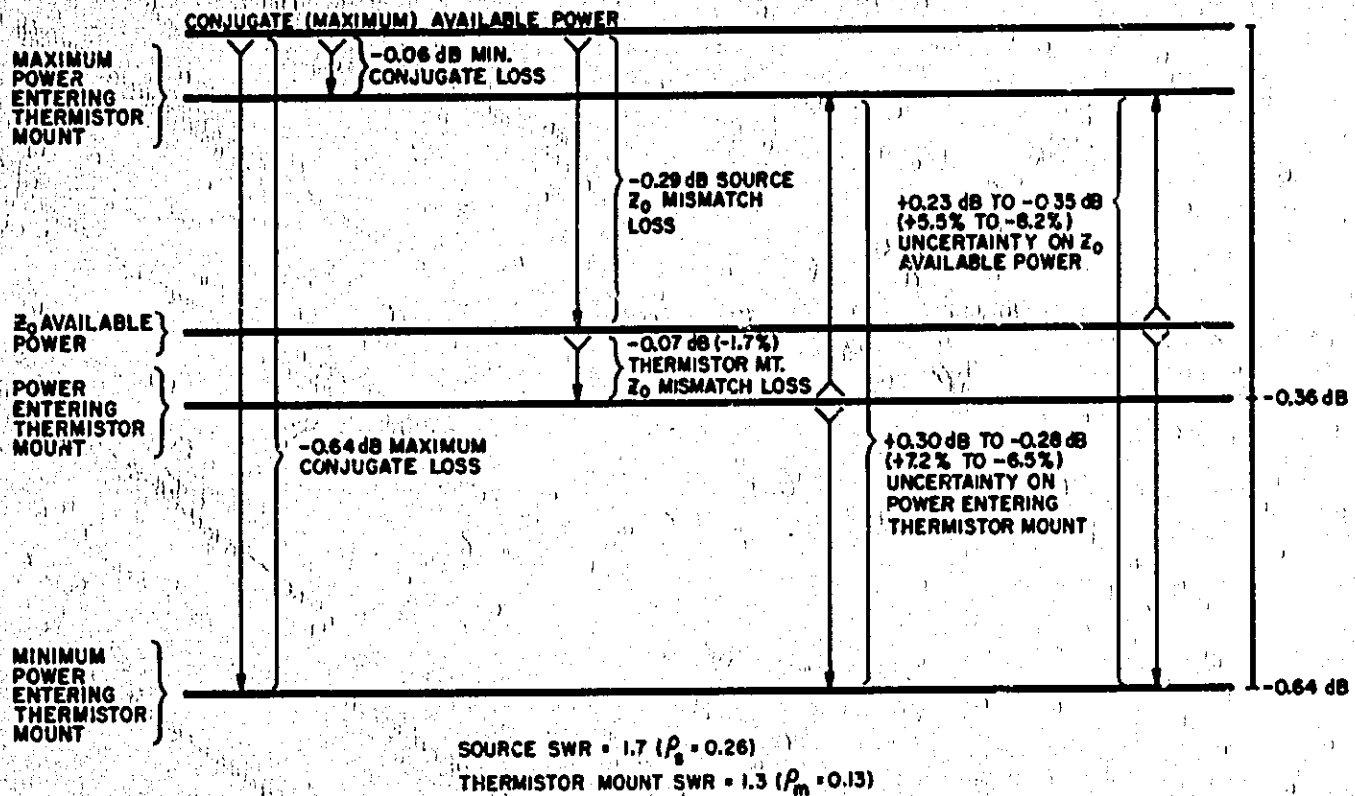

Figure 3-2. Mismatch Power Measurement Uncertainty

3-26. RF LOSSES AND DC-TO-MICROWAVE SUBSTITUTION ERROR. RF losses account for the power entering the thermistor mount but not dissipated in the detection thermistor element. Such losses may be in the walls of a waveguide mount, the center conductor of a coaxial mount, capacitor dielectric, poor connections within the mount, or due to radiation. DC-to-microwave substitution error is caused by the difference in heating effects of the substituted audio bias or DC power and the RF power in a thermistor. The difference results from the fact that the spatial distributions of voltage, current, and resistance within the thermistor element are not the same for audio, DC and RF power. RF losses and DC-to-microwave substitution error are generally combined for the simplicity of analysis.

3-27. THERMOELECTRIC EFFECT ERROR. A mild thermocouple exists at each point of contact where the connecting wires join to the thermistor elements. Each thermocouple creates a DC voltage. Thus, two thermocouple voltages of opposite relative polarity are formed, one at each junction to each thermistor element.

3-28. Ideally, each thermocouple voltage would be equal in magnitude so that they cancel with no resultant effect on the accuracy of power measurement. In practice, however, each point of contact does not have identical thermocouple characteristics, and in addition, the temperatures at each junction may not be the same. These differences cause an incomplete cancellation of the thermoelectric voltages, resulting in a voltage that causes a thermoelectric effect error. The magnitude of the error is important when making DC substitution

measurements on the 0.1 mW, 0.03 mW, and 0.01 mW ranges. On other ranges, the effect is negligible. For hp mounts maximum error introduced by thermoelectric effect is about 0.3 μW and is typically 0.1 μW on the .01 mW range.

3-29. THERMOELECTRIC EFFECT ERROR CORRECTION. Use the following technique to correct for thermoelectric effect error.

- a. Measure power.
- b. Connect an hp Model 8402 Power Meter Calibrator to the power meter DC CALIBRATION jack.

Note

If a balanced thermistor mount is being used, an 8402B Calibrator is required.

- c. Zero and null power meter.
- d. By DC Substitution (see Figure 3-9), duplicate power measurement made in step a. Calculate and record substituted power as P₁.
- e. Reverse connection polarity between the calibrator and power meter.
- f. Re-zero and re-null power meter, if necessary.
- g. By DC Substitution, duplicate power measurement made in step a. Calculate and record substituted power as P₂.
- h. Calculate arithmetic mean of the two substitution powers P₁ and P₂. This mean power includes a correction for thermoelectric effect error.

$$\text{Power} = \frac{P_1 + P_2}{2}$$

3-30. INSTRUMENTATION ERROR. The degree of inability of the instrument to measure the true substitution audio bias or DC power supplied to the thermistor mount is called power meter accuracy or instrumentation error. Instrumentation error of the Model 431C is $\pm 2\%$ of full scale, $+20^\circ\text{C}$ to $+35^\circ\text{C}$. Instrumentation error can be reduced to $\pm 0.1\%$ of reading, or less, by using DC substitution as described in Figure 3-9.

3-31. CALIBRATION FACTOR AND EFFECTIVE EFFICIENCY.

3-32. Calibration Factor and Effective Efficiency are two power ratios used as correction factors to improve overall accuracy of microwave power measurement. The ratios are used under different measurement conditions. Calibration Factor is used when the thermistor mount is coupled to the RF source without a tuner. Calibration Factor corrects for both SWR and inefficiency of the thermistor mount. Effective Efficiency is used when a tuner matches the source to the thermistor mount. Effective Efficiency corrects only for the inefficiency of the thermistor mount.

3-33. Each thermistor mount has a particular impedance. This impedance, and hence the mount SWR, remain constant over the major portion of the microwave band for which the mount is designed to operate. For hp thermistor mounts this constant SWR is low; thus the mismatch uncertainty is small. Since the mount impedance and corresponding SWR deviate significantly only at the high and low ends of a microwave band, it is generally unnecessary to use a tuner. However, a tuner or other effective means of reducing mismatch error is recommended when the source SWR is high or when high accuracy is required. To minimize mismatch between the source and the thermistor mount without the use of a tuner, a low SWR precision attenuator can be inserted in the transmission line to isolate the thermistor mount from the source. Since a tuner is not often used, Calibration Factor is a more practical term than Effective Efficiency.

3-34. CALIBRATION FACTOR. Calibration Factor is the ratio of substituted audio or DC power in the thermistor mount to the microwave RF power incident upon the mount.

$$\text{Calibration Factor} = \frac{P_{DC} \text{ Substituted}}{P_{\text{microwave Incident}}}$$

Calibration Factor is a figure of merit assigned to a thermistor mount to correct for the following sources of error: 1) RF reflected by the mount due to mismatch, 2) RF loss caused by absorption within the mount but not in the thermistor element, and 3) DC-to-microwave substitution error.

3-35. The CALIB FACTOR switch on the front panel allows rapid power measurements to be made with improved accuracy. The switch is set to the Calibration Factor value, appropriate to the frequency of measurement, imprinted on the thermistor mount label. With the proper setting, the 431C compensates for the Calibration Factor of the thermistor mount.

3-36. Calibration Factor is applied as a correction factor to all measurements made without a tuner. Under this condition, the power indicated is the power that would be delivered by the source to a load impedance equal to Z_0 . This measured power is called Z_0 available power.

3-37. Calibration Factor correction ensures that a power measurement uncertainty range is centered on the Z_0 available power level instead of on the power delivered to the thermistor mount impedance. Total measurement uncertainty limits for a given power measurement using Calibration Factor are the sum of the uncertainties contributed by: 1) Mismatch loss, 2) Calibration Factor uncertainty, and 3) Instrumentation error.

3-38. An example of power measurement uncertainty caused by source and thermistor mount mismatch is given in Paragraphs 3-23 through 3-25. Continuing the example will show the basic principle of Calibration Factor correction to a measurement of Z_0 available power. Figure 3-3 shows the relationship and limits of error before correction. A source SWR of 1.7 and a thermistor mount SWR of 1.3 result in a Z_0 available power uncertainty of $+5.5\%$ to -8.2% . Assuming a thermistor mount Calibration Factor of 94% (accuracy of $\pm 2\%$), the Calibration Factor uncertainty is $(-6\%) + (\pm 2\%)$, or -4% to -8% . The 431C Power Meter has an instrumentation error of $\pm 1\%$ (may be reduced by DC substitution, Figure 3-9). The algebraic addition of Calibration Factor, instrumentation and Z_0 available power uncertainties determines the limits of error before Calibration Factor correction. In this case, the limits are $+2.5\%$ to -17.2% .

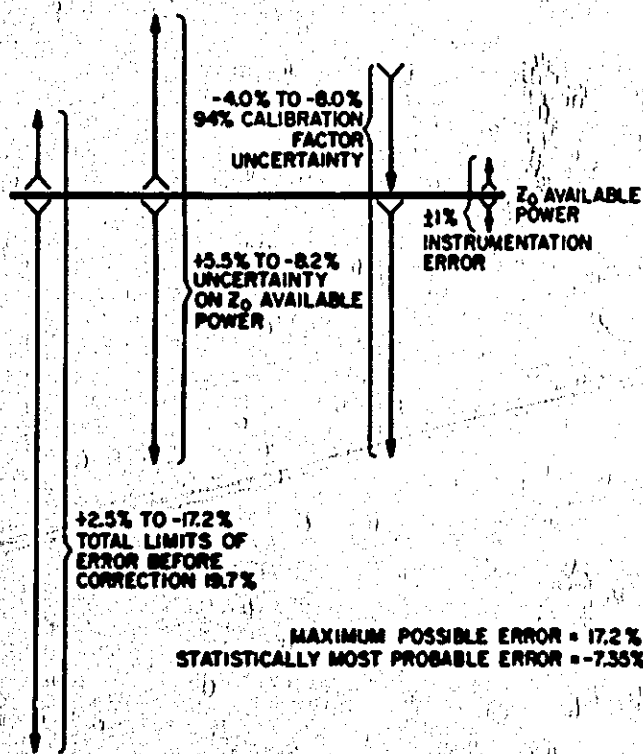

Figure 3-3. Limits of Error Before Correction

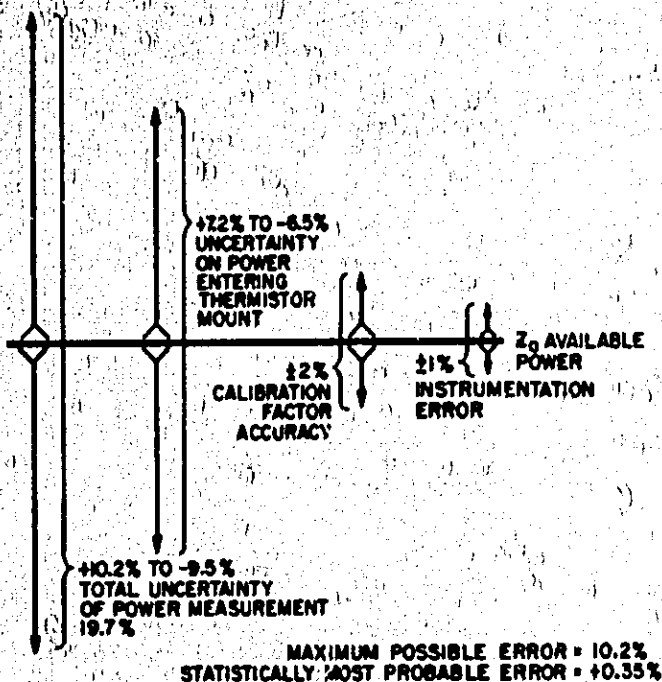

Figure 3-4. Total Uncertainty After Correction

Before correction, the maximum possible error is 17.2% and the statistically most probable error is -7.35%.

3-39. Figure 3-4 shows the total power measurement uncertainty after Calibration Factor correction. Note that the range of uncertainty, 19.7%, is the same as it was before correction. However, the measurement uncertainty range has shifted, and is now more symmetrical about the Z_0 available power level.* The total uncertainty after correction is the algebraic sum of the instrumentation error ($\pm 1\%$), the accuracy to which Calibration Factor is determined ($\pm 2\%$), and the uncertainty on the power actually entering the thermistor mount. After correction, the power measurement uncertainty on the Z_0 available power is +10.2% to -9.5%. The maximum possible error is 10.2% (was 17.2%) and the statistically most probable error is +0.35% (was -7.35%). This is a typical example showing how the use of Calibration Factor correction to a measurement of Z_0 available power not only reduces the maximum possible error, but more importantly, the magnitude of the statistically most probable error is reduced to very near the Z_0 available power level.

*The relationship between indicated power on the 431C and the Z_0 available power is given by the following equation:

$$P_0 = \frac{P \text{ Indicated } (1 \pm \rho_s \rho_m)^2}{\text{Calibration Factor}}$$

Where: P_0 = Z_0 available power
 ρ_s = source reflection coefficient
 ρ_m = thermistor mount reflection coefficient
 $\rho = \frac{SWR - 1}{SWR + 1}$

3-40. **EFFECTIVE EFFICIENCY.** Effective Efficiency is the ratio of substituted audio or DC power in the thermistor mount to the microwave RF power dissipated within the mount.

$$\text{Effective Efficiency} = \frac{P_{DC \text{ Substituted}}}{P_{\mu\text{wave Dissipated}}}$$

This power ratio corrects for RF losses and DC-to-microwave substitution error in the thermistor mount. It is largely independent of the level of input RF power. When a tuner is used to present either a conjugate or Z_0 match to the microwave RF source, Effective Efficiency is to be applied as a correction factor to the power measurement because all of the power incident upon the mount is absorbed in the mount. The use of a tuner and application of Effective Efficiency is the most accurate method of measuring power since source and thermistor mount power reflections are eliminated, and thus, measurement uncertainty due to mismatch is eliminated. Tuner loss will generally be small. However, its effects on power measurement can be corrected for by dividing the indicated power by the tuner-loss ratio, power out/power in.

3-41. Effective Efficiency can be applied as a correction factor to both conjugate available and Z_0 available power measurements. The CALIB FACTOR switch is set to the Effective Efficiency value, appropriate to the frequency under test, imprinted on the thermistor mount label. The type of application of the tuner determines if the power measured is conjugate available or Z_0 available.

3-42. Conjugate available power is measured when the system consisting of the RF source, transmission line, tuner and thermistor mount is tuned for a maximum power level on the 431C. In this application, the system-mount combination presents a conjugate match to the source. The power measured is the actual power that would be delivered by the source to a conjugate load.

3-43. Z_0 available power is measured when a tuner-thermistor mount combination is tuned for minimum reflection caused by mount mismatch at the frequency of interest. The tuner adjustment is made on a reflectometer or slotted line system, external to the measurement system used for power measurement. After the tuner adjustment, the tuner-thermistor mount combination is connected to the transmission line and RF source on which a power measurement is made.

3-44. HIGH ACCURACY OF POWER MEASUREMENT USING DC SUBSTITUTION.

3-45. The instrumentation source of error can be reduced by using DC substitution. With precision instruments used in a DC substitution set up, and careful procedure, instrument error can be reduced from $\pm 1\%$ of full scale to $\pm 0.16\%$ of reading, or less. The technique involves: 1) applying the RF power to be measured to the thermistor mount and noting the power meter reading, 2) removing the RF power from the thermistor mount and substituting a DC current from an external DC power source to precisely duplicate the meter reading obtained in step 1, and 3) calculating the power from the substituted DC current and thermistor operating resistance.

3-46. **EQUIPMENT USED FOR DC SUBSTITUTION.** Figure 3-9 shows the instrument setup for a DC

substitution measurement. The hp Model 8402B Calibrator conveniently provides DC power and appropriate switching to perform DC substitution measurement with the Model 431C. If the 431C is being used with a balanced 200 ohm thermistor mount, the 8402B must be used. If the 431C is used with an unbalanced thermistor mount such as hp Model 478A Coaxial or 486A Waveguide types, the 8402B may be replaced with an 8402A Power Meter Calibrator.

3-47. Although the DC substitution technique is the most accurate method of measuring RF power, there are sources of error that must be considered. The accuracy of DC substitution depends largely upon: 1) how accurately substituted DC is known, 2) how precisely the power meter reading is duplicated, and 3) the actual operating resistance of the thermistor.

3-48. **SUBSTITUTION FUNCTION MEASUREMENT ACCURACY.** Voltmeter terminals are located on the rear panel of the 8402B Calibrator. These terminals provide a means to monitor the magnitude of calibrator output currents by presenting a DC voltage proportional to the substituted current. For the purpose of calculating a substituted power, this voltage carries a total uncertainty of $\pm 0.12\%$. This uncertainty includes a $\pm 0.08\%$ uncertainty of the thermistor resistance function of the calibrator (steps 8 through 11 of Figure 3-9). However, the output impedance of this voltage is finite (100 ohms on 1.0 mW through 10 mW ranges; 1 kohms on lower ranges). This output impedance requires the use of a differential or high impedance voltmeter in order to obtain an accurate measurement of the calibrator output. At null, a differential voltmeter does not draw current from the calibrator voltage output circuitry. For this reason, a differential voltmeter will not introduce measurement error due to loading. When using a voltmeter other than a differential type, correction must be made for the measurement error that is introduced by the voltmeter input impedance. For example, a digital voltmeter with an input impedance of 1 megohm will introduce a measurement error of 0.1% when used to measure calibrator output on ranges below 1.0 mW. Substitution current measurement error corrections must be doubled since the power measured is proportional to the square of the substituted current. Twice the voltage uncertainty is the power uncertainty introduced by the voltmeter. Therefore, the correction to be applied in the above

example is 0.2%. Corrections should be added to voltmeter readings since voltmeter impedance loading causes voltage measurements to decrease.

3-49. **POWER METER DVM OUTPUT MEASUREMENT.** A digital voltmeter can be connected to the 431C DVM jack to increase resolution of a power meter reading. This feature provides a convenience to the operator and allows an easy method of repeating a precise measurement readout value. Measurement error corrections for voltmeter impedance loading must be made when using a voltmeter to measure the voltage output of the 431C Power Meter. The DC voltage at the DVM jack on the rear panel is developed across a 1 k ohm resistor. Therefore, a voltage measurement made with a digital voltmeter having an input impedance of 500k ohms will introduce an error of 0.2%. A digital voltmeter with an input impedance of 10 megohms will introduce a much smaller error of 0.01%. Correction percentages should be added to voltmeter readings.

3-50. **DETECTION THERMISTOR RESISTANCE.** Steps 8 through 11 of Figure 3-9 list a procedure to determine the operating resistance of the RF detection bridge at balance and thus measure the operating resistance of the detection thermistor element (R_d) during a power measurement. The actual operating resistance of detection thermistors may deviate as much as $\pm 0.5\%$ from their nominal values. For this reason, the actual operating resistance should be checked. The true operating resistance must be known in order to accurately calculate substituted DC power in a DC substitution measurement.

3-51. The hp Model 8402B Calibrator provides a convenient method of determining the detection thermistor operating resistance. The thermistor mount cable is connected between the 431C Power Meter THERMISTOR MOUNT and 8402B Calibrator RESISTANCE STANDARD connectors. By the THERMISTOR RESISTANCE switch, the 8402B Calibrator substitutes precision resistance values in place of the thermistor elements normally in the 431C bridge circuits. The switched resistances provide a method of determining a oscillation/no-oscillation state of the 431C Power Meter.

3-52. With the 431C RANGE switch at NULL, a stable reading greater than zero indicates an audio-bias oscillation state. While changing the substituted resistances, the operator can determine when oscillations

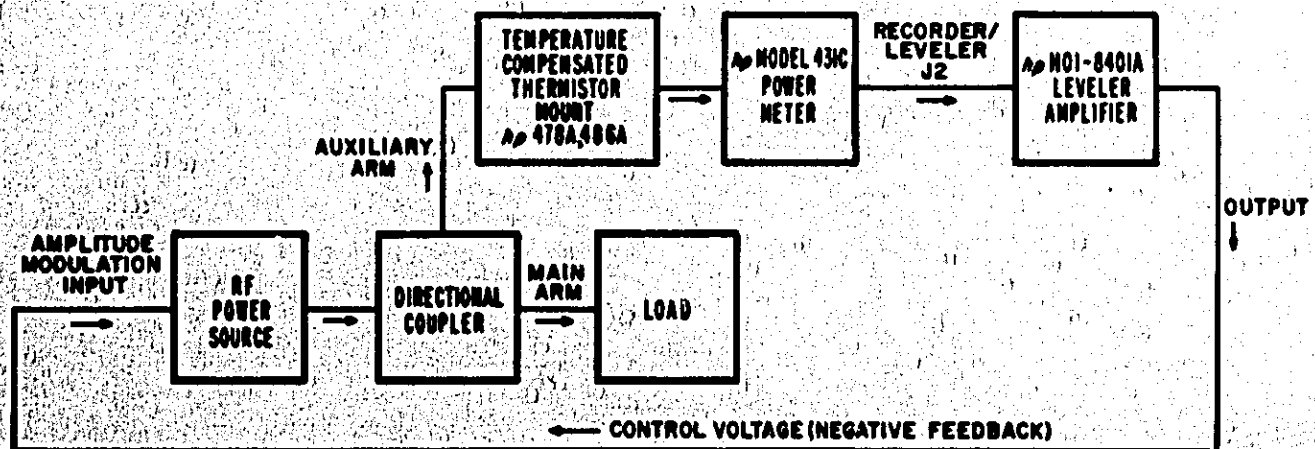

Figure 3-5. Output Power Leveling

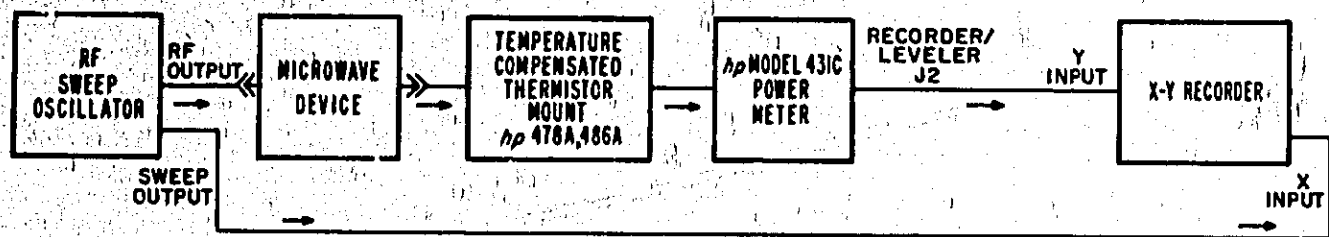

Figure 3-6. Insertion Loss or Gain Measurement

cease by noting a change of meter reading to zero. The operating resistance of the detection thermistor element is measured by reading the resistance deviation in percent directly from the switch setting that causes oscillations to cease.

3-53. ADDITIONAL APPLICATIONS.

3-54. A discussion of microwave power measurement applications is available in Application Note 64, available from any Hewlett-Packard Sales and Service office. The RECORDER/LEVELER output allows the 431C to be used in systems of greater capability than would be possible with a meter indication alone. Important applications include: 1) permanent recording of measurement data, 2) output power leveling, 3) insertion loss or gain measurement and, 4) control system monitoring. These applications are discussed in the following paragraphs. Other applications include readout of the level of a microwave RF power source at a remote location, and using the ratio of two power meter DVM outputs to make precise measurements of small attenuations.

3-55. OUTPUT POWER LEVELING. A block diagram of an output power leveling system is shown in Figure 3-5. The power meter is used as an element in a control circuit that maintains a constant power level at a particular point in the system. The thermistor mount, connected to the auxiliary arm of a directional coupler, senses a portion of the power incident upon the directional coupler. The power meter RECORDER/LEVELER output provides a DC voltage that is proportional to the power measured at the thermistor mount. This voltage can be directly applied to the power meter leveling input of one of the hp Model 690 Sweep Oscillators, or to the input of a leveler amplifier. At the

leveler amplifier, the voltage is compared to an internal reference, the difference voltage amplified, and applied as negative feedback to the amplitude modulation input of the source. The feedback maintains a constant RF power level at the sampling point on the auxiliary arm of the directional coupler. This control will hold the forward power at the main arm of the coupler at a constant level.

3-56. INSERTION LOSS OR GAIN. Figure 3-6 shows a block diagram of a system to determine insertion loss or gain as a function of frequency. Initially, the device to be tested is not connected into the system and the thermistor mount is connected directly to the sweep oscillator output. Variations in power amplitude are measured by the power meter as the frequency range of interest is swept by the sweep oscillator. This is a reference measurement and is recorded by the X-Y recorder. The device to be tested is then inserted between the sweep oscillator and the thermistor mount. Power amplitude versus frequency is again measured and recorded. The difference between the second reading and the reference, at any frequency, is the insertion loss or gain of the device at that frequency.

3-57. CONTROL SYSTEM MONITORING. The arrangement of a system to actuate alarm or control circuits is shown in Figure 3-7. A relay circuit can be connected directly to the RECORDER/LEVELER output. This type of circuit will provide a control system operated by full-scale magnitude power changes of the power meter. Small magnitude power change control can be achieved through the use of a comparison reference level and a differential amplifier. The differential amplifier output can be connected to the relay circuit to actuate the alarm or control circuits.

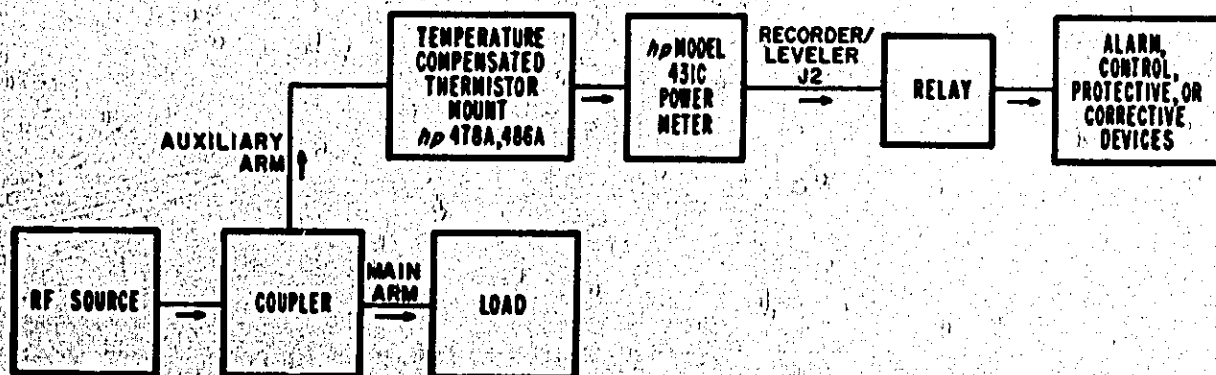
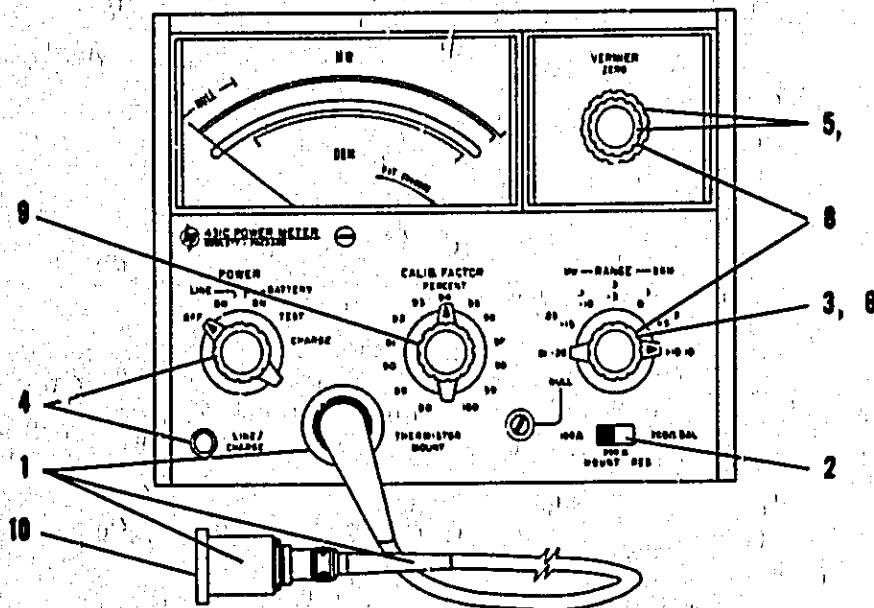

Figure 3-7. Control System Monitoring



1. Connect thermistor mount and cable to **THERMISTOR MOUNT** connector. Refer to Table 1-2 for recommended thermistor mounts and their frequency ranges.

Meter Mechanical Zero:

- a. With instrument turned off, rotate meter adjustment screw clockwise until pointer approaches zero mark from the left.
- b. Continue rotating clockwise until pointer coincides with zero mark. If pointer overshoots, continue rotating adjustment screw clockwise until pointer once again approaches zero mark from the left.
- c. Rotate adjustment screw about three degrees counterclockwise to disengage screw adjustment from meter suspension.

Note

When using an hp Model 478A or other 200 ohm unbalanced coaxial thermistor mount, the power meter should be zeroed and nulled with the RF power source turned off and connected to the thermistor mount. If the RF power source cannot be turned off, the power meter must be zeroed and nulled while the RF input connection of the thermistor mount is terminated in the same 10kHs impedance as that presented by the power source (short, open, or 50 ohm). These precautions are not necessary when waveguide mounts such as the hp Model 486A series or balanced 200 ohm coaxial mounts are used.

2. Set **MOUNT RES** switch to correspond to the operating resistance and type of thermistor mount used.

CAUTION

To avoid severe damage to the thermistor mount, be careful not to move the **MOUNT RES** switch while operating the **RANGE** switch.

3. Set **RANGE** to .01 mW.
4. Set **POWER** to **LINE ON**. If instrument is to be battery operated, rotate **POWER** to **BATTERY ON**.
5. Adjust **ZERO** control for 25% to 75% of full scale on meter.
6. Rotate **RANGE** switch to **NULL** and adjust **NULL** screwdriver adjustment (adjacent to **NULL** on **RANGE** switch) for minimum reading.
7. Repeat steps 5 and 6 until **NULL** reading is within **NULL** region on the meter.
8. Set **RANGE** switch to the power range to be used and zero-set the meter with **ZERO** and **VERIFIER** controls.

Note

Range-to-range zero carryover is less than $\pm 1.0\%$ if the meter has been properly adjusted mechanically (Step 1 above) and the instrument has been properly zero-set electrically on its most sensitive range. For maximum accuracy, zero-set the power meter on the range to be used.

9. Set **CALIB FACTOR** switch to correspond with Calibration Factor imprinted on hp thermistor mount label.
10. Apply RF power at the thermistor mount. Power is indicated on the meter directly in mW or dBm.

Figure 3-8. Turn On and Nulling Procedure

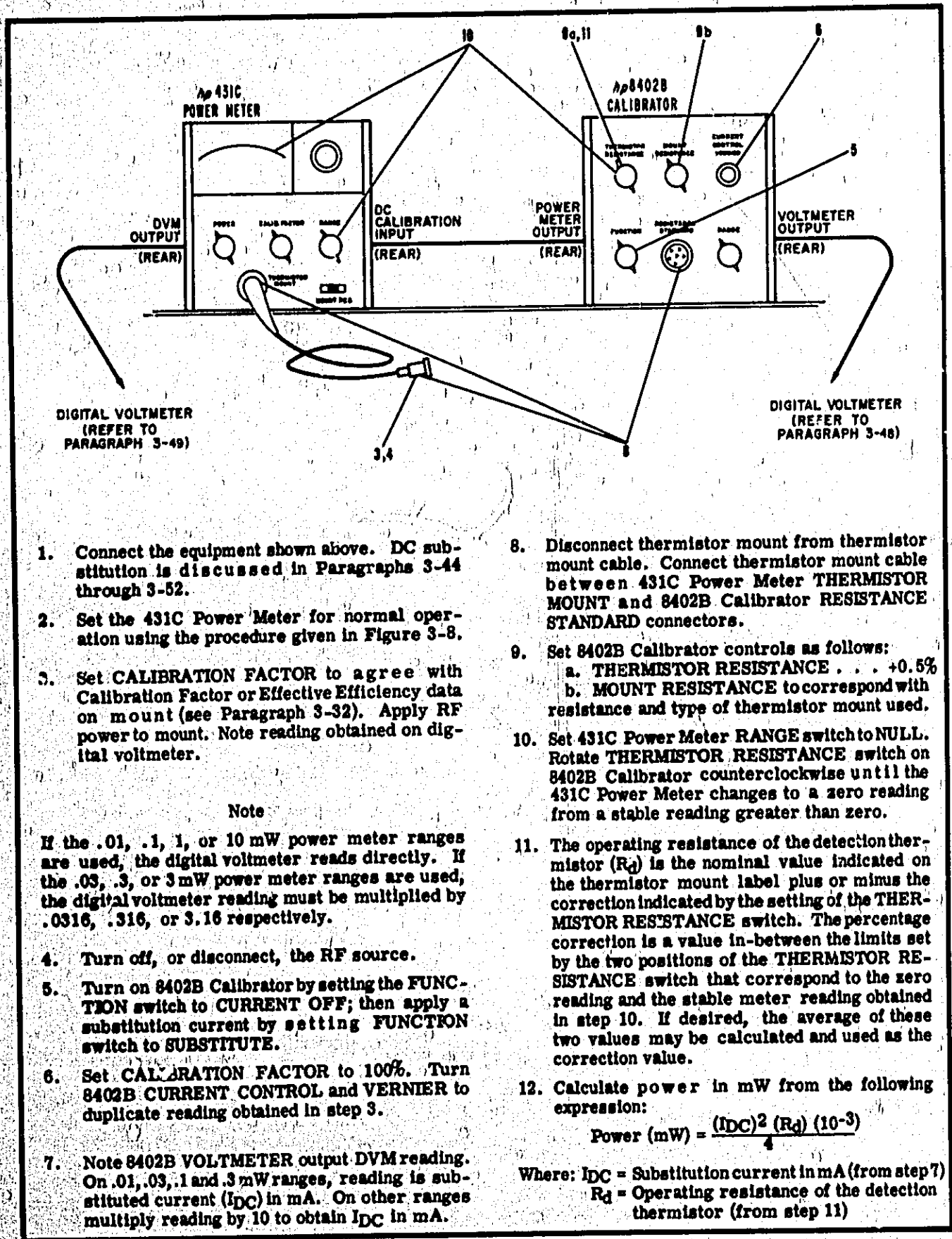

1. Connect the equipment shown above. DC substitution is discussed in Paragraphs 3-44 through 3-52.
2. Set the 431C Power Meter for normal operation using the procedure given in Figure 3-8.
3. Set CALIBRATION FACTOR to agree with Calibration Factor or Effective Efficiency data on mount (see Paragraph 3-32). Apply RF power to mount. Note reading obtained on digital voltmeter.

Note

If the .01, .1, 1, or 10 mW power meter ranges are used, the digital voltmeter reads directly. If the .03, .3, or 3 mW power meter ranges are used, the digital voltmeter reading must be multiplied by .0316, .316, or 3.16 respectively.

4. Turn off, or disconnect, the RF source.
5. Turn on 8402B Calibrator by setting the FUNCTION switch to CURRENT OFF; then apply a substitution current by setting FUNCTION switch to SUBSTITUTE.
6. Set CALIBRATION FACTOR to 100%. Turn 8402B CURRENT CONTROL and VERNIER to duplicate reading obtained in step 3.
7. Note 8402B VOLT METER output DVM reading. On .01, .03, .1 and .3 mW ranges, reading is substituted current (I_{DC}) in mA. On other ranges multiply reading by 10 to obtain I_{DC} in mA.

8. Disconnect thermistor mount from thermistor mount cable. Connect thermistor mount cable between 431C Power Meter THERMISTOR MOUNT and 8402B Calibrator RESISTANCE STANDARD connectors.
9. Set 8402B Calibrator controls as follows:
 - a. THERMISTOR RESISTANCE . . . +0.5%
 - b. MOUNT RESISTANCE to correspond with resistance and type of thermistor mount used.
10. Set 431C Power Meter RANGE switch to NULL. Rotate THERMISTOR RESISTANCE switch on 8402B Calibrator counterclockwise until the 431C Power Meter changes to a zero reading from a stable reading greater than zero.
11. The operating resistance of the detection thermistor (R_d) is the nominal value indicated on the thermistor mount label plus or minus the correction indicated by the setting of the THERMISTOR RESISTANCE switch. The percentage correction is a value in-between the limits set by the two positions of the THERMISTOR RESISTANCE switch that correspond to the zero reading and the stable meter reading obtained in step 10. If desired, the average of these two values may be calculated and used as the correction value.

12. Calculate power in mW from the following expression:

$$\text{Power (mW)} = \frac{(I_{DC})^2 (R_d) (10^{-3})}{4}$$

Where: I_{DC} = Substitution current in mA (from step 7)
 R_d = Operating resistance of the detection thermistor (from step 11)

Figure 3-9. DC Substitution

SECTION IV PRINCIPLES OF OPERATION

4-1. BLOCK DIAGRAM.

4-2. The Model 431C Power Meter measures microwave power indirectly using two bridge circuits (refer to Figure 4-1). The detection bridge incorporates a 10-kHz oscillator whose amplitude is determined by the amount of microwave power heating the thermistors in that bridge.

4-3. The compensation and metering bridge contains thermistors that are immersed in the same thermal environment as those of the detection bridge. It is fed the same 10-kHz bias current that flows in the detection bridge.

4-4. Unbalance in the metering bridge produces 10-kHz error signal; this, plus 10-kHz bias taken directly from the oscillator-amplifier, are mixed in the synchronous detector to produce an error-proportional direct current. Fed back to the metering bridge, dc power substitutes for the 10-kHz power in heating the thermistors and drives the bridge toward balance.

4-5. The dc output of the synchronous detector also operates the meter circuit.

4-6. CIRCUIT DESCRIPTION.

4-7. RF DETECTION BRIDGE (Figure 4-2). The RF detection bridge and the 10 kHz oscillator-amplifier are connected in a closed loop (the detection loop) which

provides positive feedback to cause oscillation. The RF bridge includes thermistor element R_d , the secondaries of transformer A1T2, capacitances C_a and C_b , and the resistive arm consisting of A1R10 and parallel resistors selected by the MOUNT RES switch.

4-8. When the power meter is off, thermistor R_d is at room temperature and its resistance is about 1500 ohms. The bridge is unbalanced. When the power meter is turned on, a large error signal is initially applied to the bridge. As this signal heats R_d , its resistance decreases toward the operating value of 100 or 200 ohms and the RF bridge approaches balance. The 10-kHz feedback diminishes until there is just sufficient power dissipated in the thermistors to maintain them at the operating resistance.

4-9. Microwave power, applied to the thermistors, heats them further; this decreases the error signal, reducing 10-kHz power just enough to balance out the microwave power.

4-10. The MOUNT RES switch, S1, changes the resistance arm of the RF detection bridge so that the bridge will function with either a 100 ohm, 200 ohm, or 200 ohm balanced thermistor mount. The 200Ω BAL position allows the power meter to be operated with balanced thermistor mounts. When the MOUNT RES switch is in this position two equal capacitors are connected in series across the thermistors with their

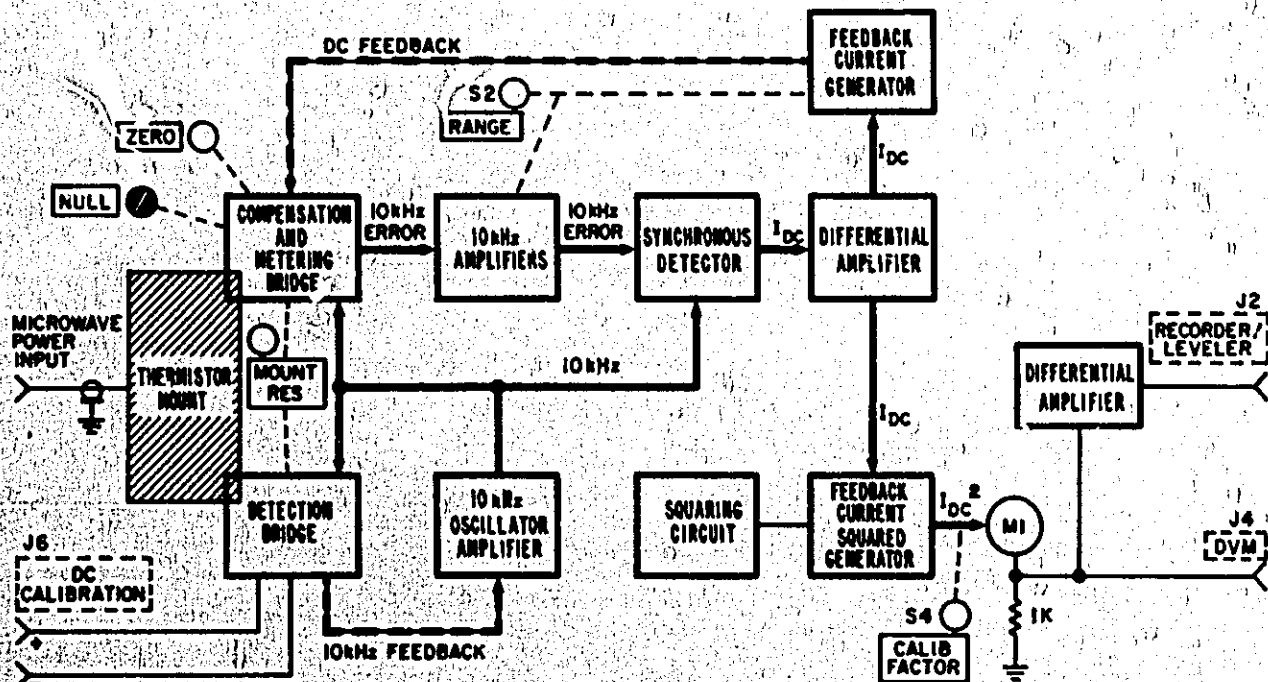

Figure 4-1. Block Diagram

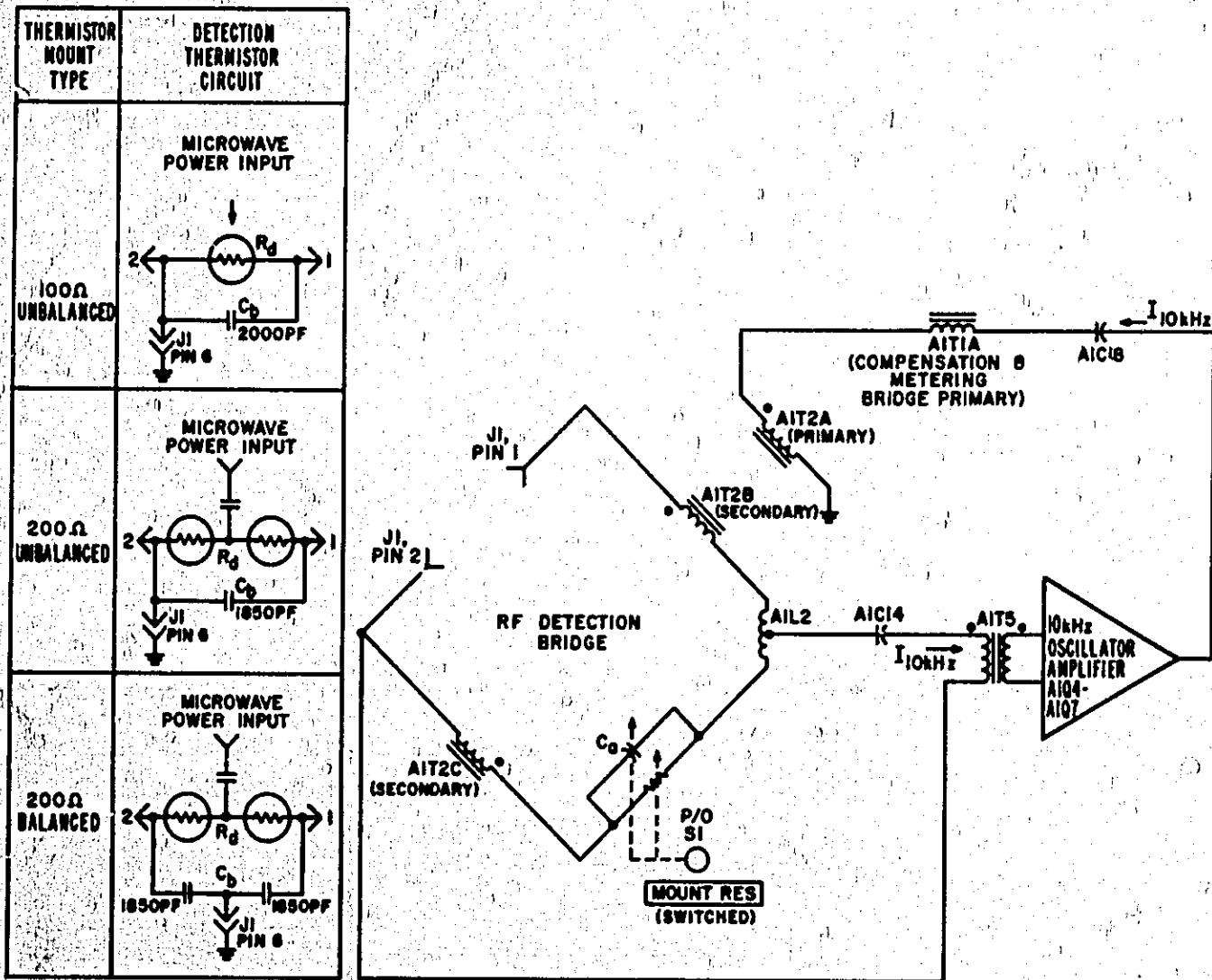

Figure 4-2. RF Detection Bridge

common point grounded. Identical capacitors are connected in a similar manner across A1R10 in the resistance arm of the RF detection bridge. All other grounds are removed from the bridge so that the entire bridge is floating with respect to DC ground. This circuit configuration provides a virtual 10 kHz ground at the RF input point to the balanced thermistor mount.

4-11. COMPENSATION AND METERING BRIDGE CIRCUIT.

4-12. A simplified schematic diagram of the compensation and metering bridge circuit is shown in Figure 4-3. Operation of the metering bridge circuit is similar to the RF detection bridge circuit. It uses the same principle of self-balancing through a closed loop (metering loop). The major difference is that DC rather than 10 kHz power is used to re-balance the loop. The resistive balance point is adjusted by the ZERO and VERNIER controls which constitute one arm

of the bridge. The MOUNT RES switch, which is mechanically linked to both the RF bridge and metering bridge, changes metering bridge reference resistance from 100 to 200 ohms. When the MOUNT RES switch is in the 200Ω or 200Ω BAL position some of the feedback current is shunted to ground through R1. This maintains the I^2R function constant when mount resistance is changed from 100 or 200 ohms. The switch also adds the necessary reactance for each position.

4-13. The same 10 kHz power change produced in the RF bridge by RF power also affects the metering bridge through the series connection of A1T1 and A1T2 primaries. Although this change of 10 kHz power has equal effect on both the RF and metering bridges, it is initiated by the RF bridge circuit alone. The metering bridge cannot control 10 kHz bias power, but the 10 kHz bias power does affect the metering circuit. Once a change in the 10 kHz bias power has affected (unbalanced) the metering bridge, a separate, closed DC feedback loop (metering loop) re-establishes equilibrium in the metering circuit.

4-14. Variations in 10 kHz bias level, initiated in the RF bridge circuit, cause proportional unbalance of the metering bridge, and there is a change in the 10 kHz error signal ($I_{10\text{ kHz}}$) applied to the 10 kHz tuned amplifiers in the metering loop. These error signal variations are amplified by three 10 kHz amplifiers, and rectified by the synchronous detector. From the synchronous detector the DC equivalent (I_{DC}) of the 10 kHz signal is returned to the metering bridge, and is monitored by the metering circuit to be indicated by the meter. This DC feedback to the metering bridge acts to return the bridge to its normal, near-balance condition.

4-15. The reactive components of the metering bridge are balanced with variable capacitor C1 and inductor

A1L1. Null adjust, C1, is an operation adjustment and L1 is a maintenance adjustment. Null adjust C1, is adjusted with the RANGE switch in the NULL position. The 10 kHz signal is taken at the synchronous detector, rectified by A1CR8, and read on the meter. The rectified signal contains both reactive and resistive voltage components of the bridge unbalance.

4-16. SYNCHRONOUS DETECTOR.

4-17. A simplified schematic of the synchronous detector is shown in Figure 4-4. The synchronous detector converts the 10 kHz error signal from the metering bridge to a varying DC signal. The detector is a bridge rectifier which has a rectifier in series with a linearizing resistance in each of its arms. Two

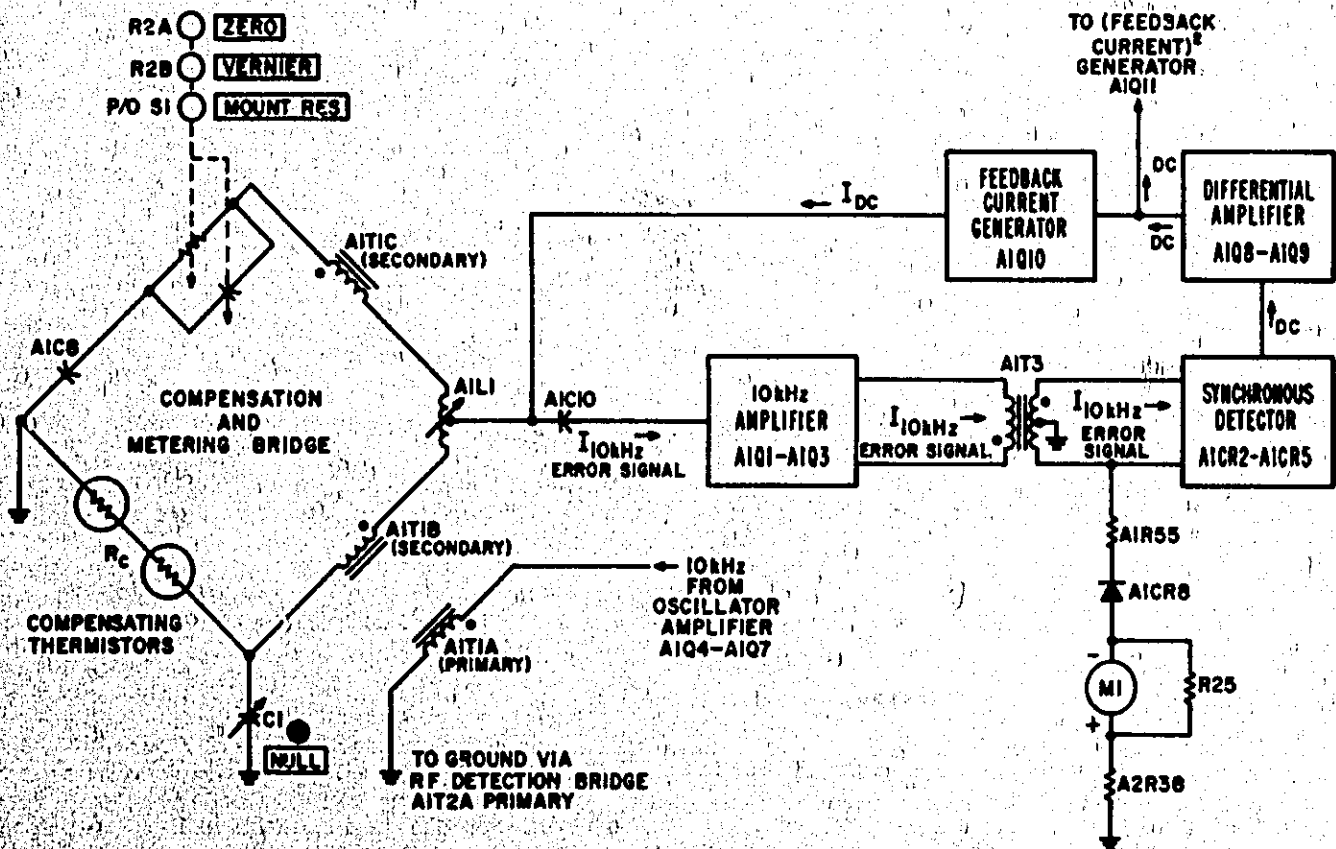
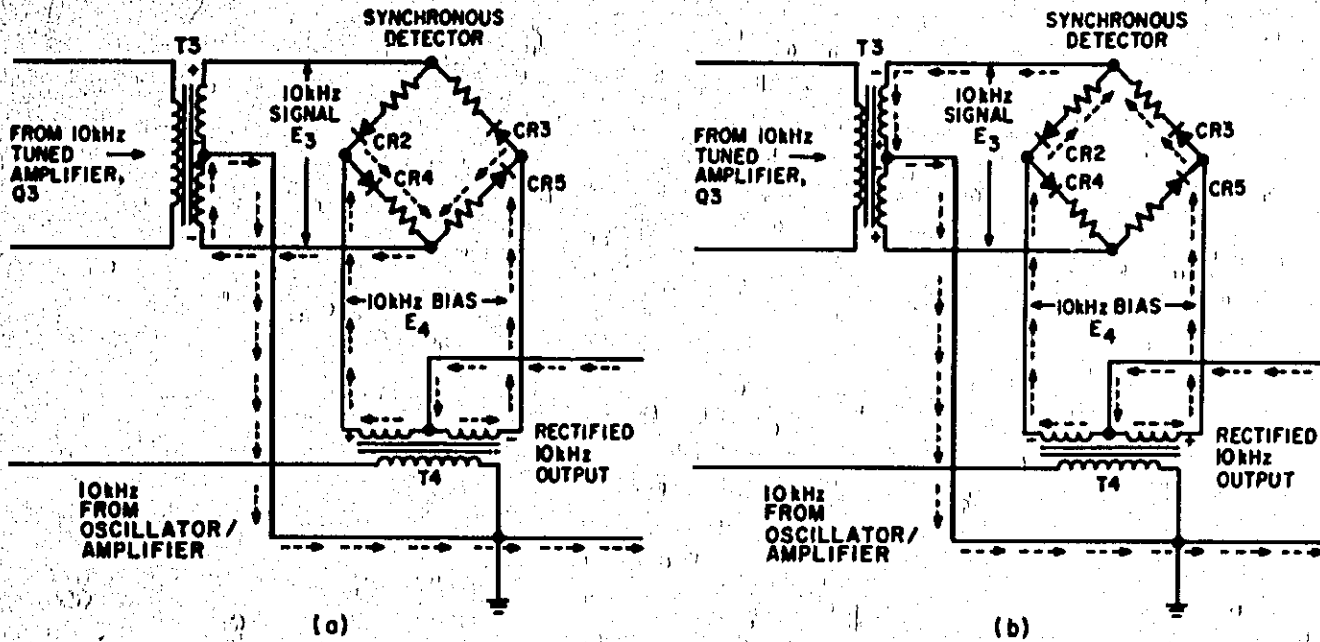

Figure 4-3. Compensation and Metering Bridge



Note: E_4 is much larger than E_3 in order to gate diodes CR2, CR3, CR4, and CR5.

Figure 4-4. Synchronous Detector

10 kHz voltages, designated E_3 and E_4 in Figure 4-4, are applied to the bridge; 1) voltage E_3 , induced in the secondary of transformer A1T3, is proportional to the metering bridge error signal and is incoming from 10 kHz tuned amplifier Q3; 2) voltage E_4 , induced in the secondary of A1T4, is proportional to a voltage supplied by the 10 kHz oscillator-amplifier. Voltage E_4 is much larger than voltage E_3 and switches appropriate diodes in and out of the circuit to rectify voltage E_3 . Section (a) of Figure 4-4 shows the current path through diodes A1CR2 and A1CR3 for a negative-going signal. The rectified output is taken at the center taps of transformers A1T3 and A1T4.

4-18. The synchronous detector operates in the following manner. When the left side of A1T4 is positive with respect to the right side, as in Figure 4-4(a), diodes A1CR4 and A1CR5 conduct while diodes A1CR2 and A1CR3 are biased off. With the polarities reversed, as in Figure 4-4(b), the diodes A1CR4 and A1CR5 are biased off. The resultant output is a pulsating DC signal equivalent to the applied 10 kHz error signal. The

pulsating DC signal is filtered and applied to differential amplifier A1Q8 and A1Q9.

4-19. The operation of the synchronous detector requires an in-phase relationship between E_3 and E_4 . The amplitude of E_4 must be greater than that of E_3 at all times.

4-20. FEEDBACK DIFFERENTIAL AMPLIFIER.

4-21. A simplified schematic diagram of the feedback differential amplifier is shown in Figure 4-5. The feedback circuit differential amplifier comprises A1Q8, A1Q9 and associated circuitry. Pulsating DC from the synchronous detector is filtered by A1C19, A1C20, and A1R35, amplified by A1Q8 and fed to both the feedback current-squared generator A1Q11, and the feedback current generator A1Q10. Temperature compensation and low emitter circuit resistance for A1Q10 is provided by A1Q9. Diode A1CR7 protects A1Q10 and A1Q11 from excessive reverse bias when A1Q8 is not conducting.

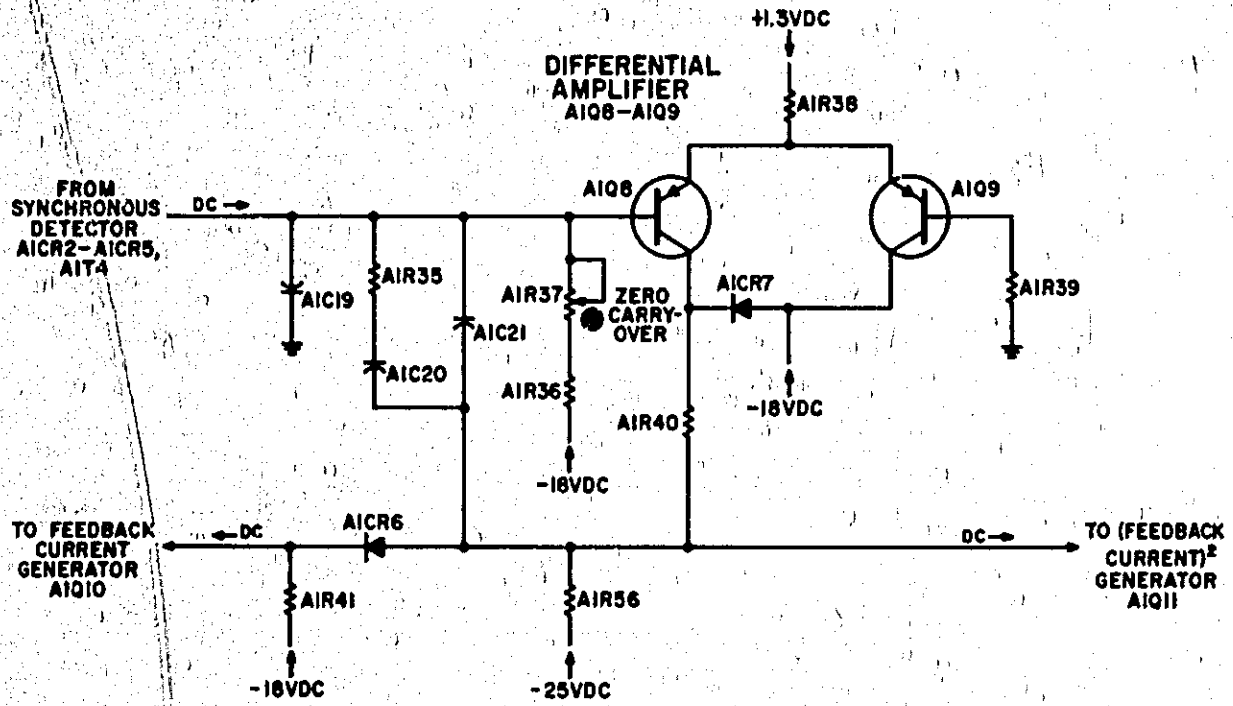

Figure 4-5. Feedback Differential Amplifier

4-22. FEEDBACK CURRENT GENERATOR.

4-23. A simplified schematic diagram of the feedback current generator is shown in Figure 4-6. The DC signal from the differential amplifier is applied to the feedback current generator A1Q10. A1Q10 serves two functions: 1) it completes the metering loop to the metering bridge, and 2) it operates in conjunction with the first 10 kHz amplifier, A1Q1, and the RANGE switch to change metering loop gain so that the meter will read full scale for each power range. Potentiometer adjustments are provided to accurately set the calibration on each range. Diode A1CR6 provides temperature compensation for A1Q10.

4-24. METER CIRCUIT.

4-25. A simplified schematic diagram of the meter circuit is shown in Figure 4-7. The meter circuit includes feedback current-squared generator A1Q11, a squaring circuit, the meter, RECORDER/LEVELER and DVM jacks, J2 and J4. The purpose of the meter circuit is to convert a linear voltage function, proportional to the square root of applied power, to a square function so that power may be indicated on a linear meter scale. The linear voltage function is applied to the base of A1Q11 and is converted to a square law function by the squaring circuit in series with A1Q11 emitter.

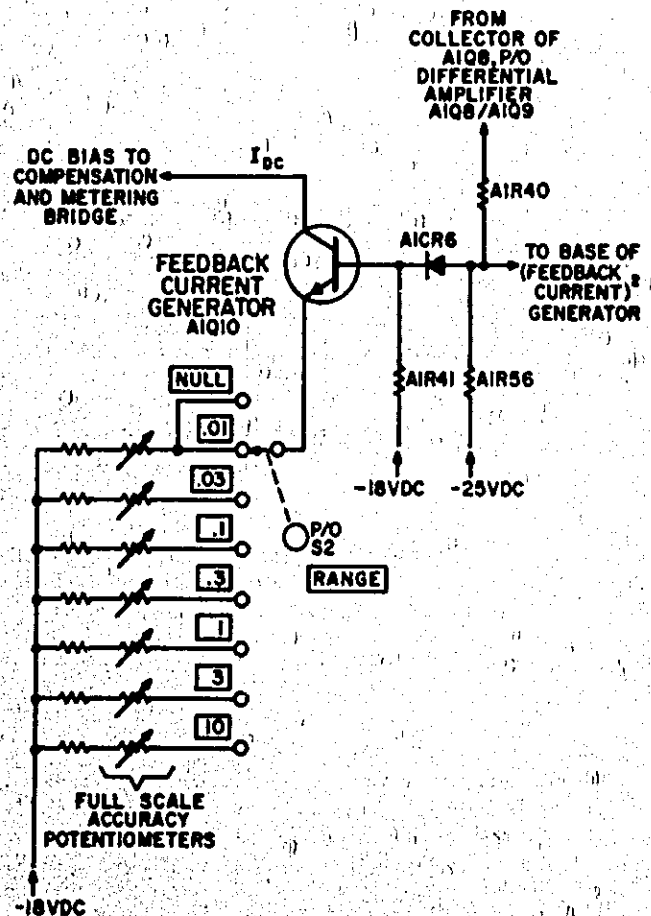

Figure 4-6. Feedback Current Generator

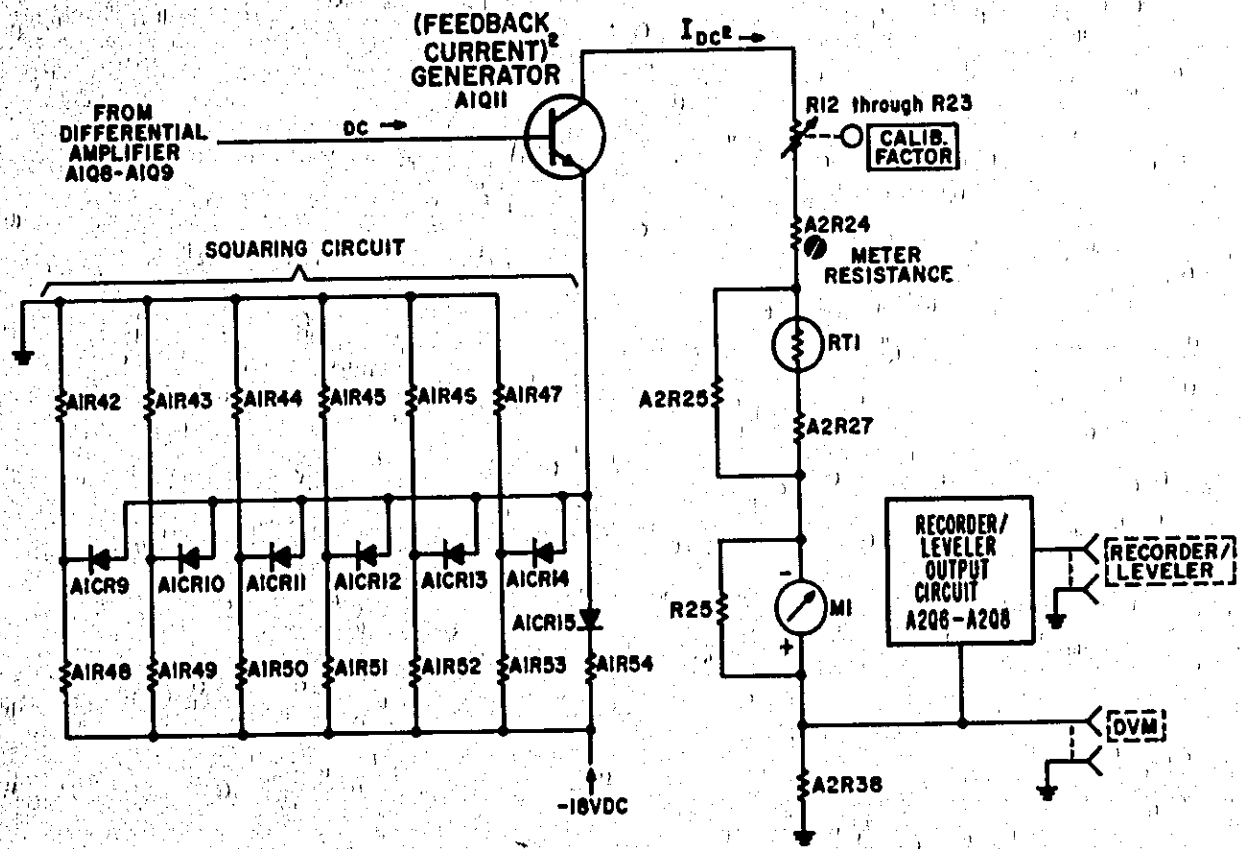

Figure 4-7. Meter Circuit.

4-26. METERING CIRCUIT DIFFERENTIAL AMPLIFIER.

4-27. The metering circuit RECORDER/LEVELER output is a voltage of low source impedance necessary for isolation between a recorder or leveler amplifier and the metering circuit of the power meter. The isolation circuit comprises the differential amplifier A2Q6-A2Q7 and output transistor A2Q8. The voltage developed across A2R38 for the DVM output is referenced at the base of A2Q6 for comparison to the voltage at the RECORDER/LEVELER jack placed on the base of A2Q7. Any difference voltage creates an error voltage that changes the base-emitter bias on A2Q8. A corresponding change in A2Q8 collector current occurs and the RECORDER/LEVELER voltage across A2R41 automatically adjusts to maintain the same magnitude as the DVM reference voltage.

4-28. SQUARING CIRCUIT. A simplified schematic diagram of the squaring circuit is shown in Figure 4-7. The squaring circuit includes diodes A1CR9-14, and resistors A1R42-54. Temperature compensation for the squaring circuit is provided by A1CR15.

4-29. The design of the squaring circuit is such that individual diodes are normally reverse-biased. The diodes are biased so that they conduct one after another at discrete values of emitter voltage. This causes the emitter resistance to be proportionately greater for

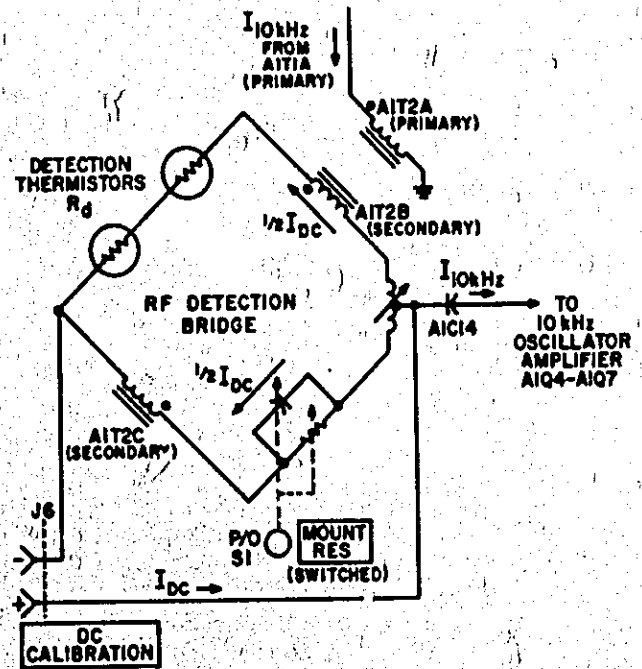

Figure 4-8. DC Calibration and Substitution

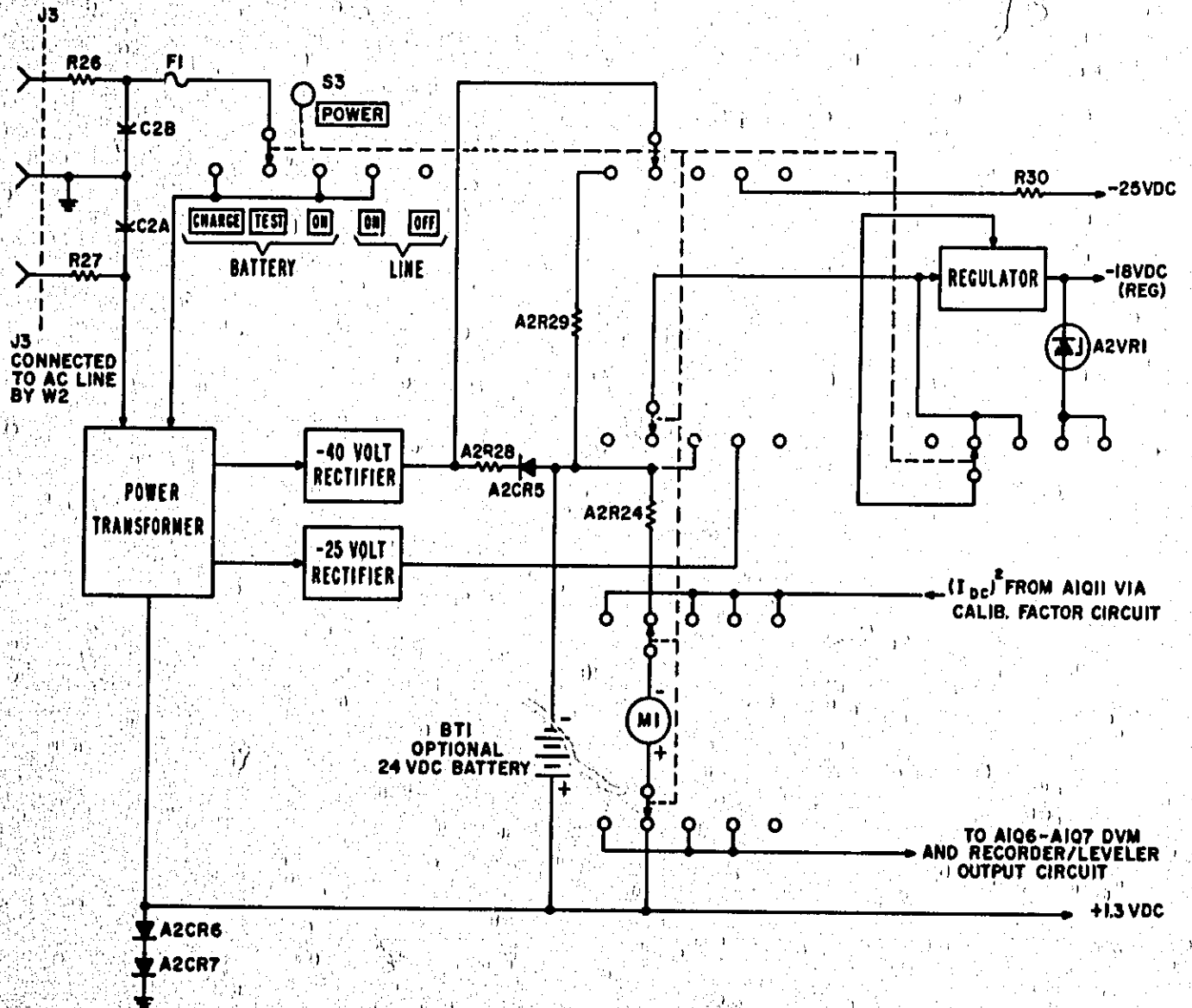

Figure 4-9. Power Switch Arrangement

larger currents. Thus, the collector current of A1Q11 is made to approximate a square law function, and the meter indicates power on a linear scale.

4-30. ZEROING. The resistance of the Metering Bridge is never balanced. A small amount of unbalance must exist to provide error signal for the operation of the feedback loop. The Metering Bridge loop circuit is self balancing and uses DC feedback to rebalance the closed loop. Resistive balance is set by R2A and R2B ZERO controls, which are in one leg of the Metering Bridge. DC offset voltage on the base of A1Q8 determines the balance point of the close loop. A1R37, ZERO CARRYOVER sets the amount of this offset for about +50 millivolts.

4-31. DC SUBSTITUTION.

4-32. A simplified schematic diagram of the DC Substitution and Calibration circuit is shown in Figure 4-8. A block diagram of the auxiliary equipment required to perform DC substitution is presented in Figure 3-9 and discussed in Paragraphs 3-34 through 3-36. An accurately determined DC current, I_{DC} , is supplied to the DC CALIBRATION terminals on the rear panel and adjusted to allow the RF detection bridge to precisely duplicate the RF power measurement reading. Calculation of DC power from the substituted DC current gives an accurate measure of the unknown RF microwave power.

4-33. REGULATED POWER SUPPLY.

4-34. A simplified schematic diagram of the power supply is shown in Figure 4-9. The power supply operates from either a 115- or 230-volt, 50 to 400 Hz AC source or from an optional 24 volt, 30 mA rechargeable battery. Three voltages and two current outputs are provided by the power supply. Regulated

voltages of -18, +1.3, and unregulated -25 VDC operate the power meter circuits. The current outputs are used for maintaining a trickle battery charge for recharging the battery.

4-35. The -18 VDC is regulated by a conventional series regulator, A2Q1 through A2Q5. The unregulated -25 VDC is developed across A2CR1 and A2CR4. The +1.3 VDC is taken across the series diodes, A2CR6 and A2CR7. The -18 VDC supply is adjusted by A2R36.

4-36. POWER SWITCH.

4-37. A simplified schematic diagram of the power switch arrangement is shown in Figure 4-9. The

POWER switch has five positions: LINE OFF, LINE ON, BATTERY ON, BATTERY TEST, and BATTERY CHARGE. In the LINE ON position the instrument operates from the conventional line voltage. If a rechargeable battery has been installed, a trickle charge is supplied to the battery. In the BATTERY ON position, instrument operation is dependent on the battery. In the BATTERY CHARGE position, -25 volts is connected to the battery for recharging. In the BATTERY TEST position, battery voltage can be measured on the 0-3 mV scale. Battery voltage is 10 times meter scale reading. Proper charge of the battery is indicated by a reading within the BAT CHARGED region on the bottom of the meter face.

SECTION V MAINTENANCE

5-1. INTRODUCTION.

5-2. This section provides instructions for performance testing, calibration adjustments, troubleshooting and repairing the 431C Power Meter. Front panel controlled performance tests allow the instrument to be checked for conformance to specifications. If performance is not within specifications, adjustment and troubleshooting instructions are provided.

5-3. Test equipment and accessories required to perform maintenance are listed in Table 5-1. Equipment other than the recommended models can be used provided their performance equals or exceeds the critical specifications.

5-4. MECHANICAL METER ADJUSTMENT. When the meter is properly zero-set, the pointer rests over

the zero mark on the meter scale when the instrument is: 1) at normal operating temperature, 2) in its normal operating position, and 3) turned off. Set the pointer as follows to obtain best accuracy and mechanical stability:

a. Turn instrument off.

b. Rotate the meter mechanical adjustment screw clockwise until the meter pointer is to the left of zero and moving up the scale towards zero. Stop when the pointer is exactly over the zero mark. If the pointer overshoots, repeat step b.

c. When the pointer is exactly on zero, rotate the adjustment screw approximately 3 degrees counter-clockwise. This frees the adjustment screw from the meter suspension. If the pointer moves during this step, repeat steps b and c.

Table 5-1. Recommended Test Equipment

Instrument Type	Critical Specifications	Recommended Model
Direct Current Power Source	Range: 0.01 to 10 mW Accuracy: $\pm 0.1\%$	hp 8402B
Electronic Counter	Sensitivity: 4V rms Frequency: 10 kHz Accuracy: $\pm 0.01\%$ or better Resolution: Five digits	hp 5512A
DC Voltmeter	Range: 0.3 to 50 volts DC Accuracy: $\pm 0.05\%$ Input Impedance: 10 Megohms, floating	hp 3440A with 3443A plug-in or 3439A/3440A or 3430A
Ohmmeter	Range: 1 ohm to 10 Megohms Accuracy: $\pm 5\%$	hp 410B/C hp 412A hp 427A
AC Voltmeter	Range: 10 to 100 mV Accuracy: $\pm 5\%$ Input Impedance: 1 Megohm	hp 403A/B hp 427A
Oscilloscope	Bandwidth: 100 kHz Accuracy: $\pm 5\%$ Input Impedance: 1 Megohm Sensitivity: 1 mV/division	hp 140A with 1400A and 1402A plug-in units
Thermistor Mount	Refer to Table 1-2 for recommended thermistor mounts	hp 8478B hp 478A hp 486A Series
Decade Capacitor	Range: 0.0 to 0.01 μ F Capacitance per step: 100 pF Accuracy: $\pm 2\%$	General Radio 1419-B
Audio Oscillator	Frequency: 10 kHz Accuracy: $\pm 2\%$	hp 200AB hp 200CD

5-5. PERFORMANCE TESTS.

5-6. **PURPOSE.** The procedures listed in Table 5-2 test power meter performance for incoming inspection, periodic evaluation, calibration and troubleshooting. The tests can be performed without access to the instrument interior. Specifications in Table 1-1 are the performance standards. If the power meter fails to meet any of the performance test specifications, refer to the adjustment procedures. If a circuit malfunction is suspected refer to the troubleshooting paragraphs.

5-7. ADJUSTMENTS.

5-8. **GENERAL.** The following procedures outline the adjustments necessary to calibrate the power meter. The actual adjustments should be made only when it is determined that the instrument is out of adjustment, and not malfunctioning due to a circuit failure.

5-9. To avoid errors due to possible ground loop currents, isolate the power meter from ground used for

other auxiliary equipment. A power plug adapter that removes the ground connection at the line outlet can be used to isolate the power meter. Use with caution and only where company rules permit.

5-10. Several circuit component parts of the power meter are selected at the factory to meet specific circuit requirements. The factory selected parts are indicated by an asterisk on the schematic diagrams and in the replaceable parts list. Table 5-3 lists the circuit requirements for factory selected parts.

5-11. COVER REMOVAL AND REPLACEMENT.

5-12. The side covers can be removed and replaced independently of the top and bottom covers. Each side cover is held in place by four screws retained by nuts which are fastened to the side frames.

5-13. TOP COVER REMOVAL.

a. At the rear of the instrument, remove the two screws which retain the cover.

Table 5-2. Performance Tests

1. **ACCURACY:** Refer to Table 1-1 Specifications.

Meter Mechanical Zero:

- a. With instrument turned off, rotate meter adjustment screw clockwise until pointer approaches zero mark from the left.
- b. Continue rotating clockwise until pointer coincides with zero mark. If pointer overshoots, continue rotating clockwise until pointer once again approaches zero mark from the left.
- c. Rotate adjustment screw about three degrees counterclockwise to disengage screw mechanism from meter suspension.

Procedure

- a. Connect equipment as shown in Figure 3-9.
- b. Set 8402B Calibrator controls as follows:
FUNCTION CURRENT OFF
RANGE 01 mW
MOUNT RESISTANCE to correspond with resistance and type of thermistor mount used.
- c. Set 431C Power Meter controls as follows:
CALIB FACTOR 100%
POWER ON
RANGE 01 mW
MOUNT RES to correspond with resistance and type of thermistor mount used.
- d. Null and zero-set the power meter (refer to Turn-On and Nulling Procedure, Figure 3-8).
- e. Set 8402B FUNCTION switch to CALIBRATE. Successively set RANGE (mW) switch on calibrator and RANGE switch on power meter to identical range values starting with the counterclockwise position of .01 mW. The power meter should read the power set on the calibrator within $\pm 1\%$ of full scale.
- f. Set RANGE (mW) switch on calibrator and

RANGE switch on power meter to 10 mW.

g. If necessary, adjust ZERO and VERNIER controls on power meter to obtain an exact 10 mW reading.

h. Successively set RANGE (mW) switch on calibrator to 8, 6, 4, and 2 mW positions while observing power meter reading. The power meter should read the power set on the calibrator within limits in Table 1-1.

2. **ZERO CARRYOVER:** Less than 1% of full scale when zeroed on most sensitive range.
Procedure

- a. Connect hp 3440A DC Voltmeter to DVM output jack on rear of 431C Power Meter (refer to Paragraph 3-49).
- b. Set power meter controls as follows:

POWER ON
RANGE 01 mW
CALIB FACTOR 100%
MOUNT RES to correspond with resistance and type of thermistor mount used.

- c. Adjust ZERO for 0.00 VDC reading on 10 volt range of DC voltmeter.
- d. Rotate power meter RANGE switch clockwise through remaining ranges. Reading on DC voltmeter should remain within $0.00 \pm .01$ VDC on each range.

3. **DVM OUTPUT:** 1.000 VDC into open circuit corresponds to full scale meter deflection (1.0 on 0-1 scale) $\pm 0.5\%$; 1 K Ω output impedance, BNC female connector; effect of loading impedance less than 10 M Ω must be accounted for.
Procedure

- a. Perform steps a through d of ACCURACY performance test.
- b. Set 8402B FUNCTION switch to CALIBRATE. Reading on DC voltmeter should be 0.995 to 1.005 VDC, and correspond with full scale meter reading of power meter.

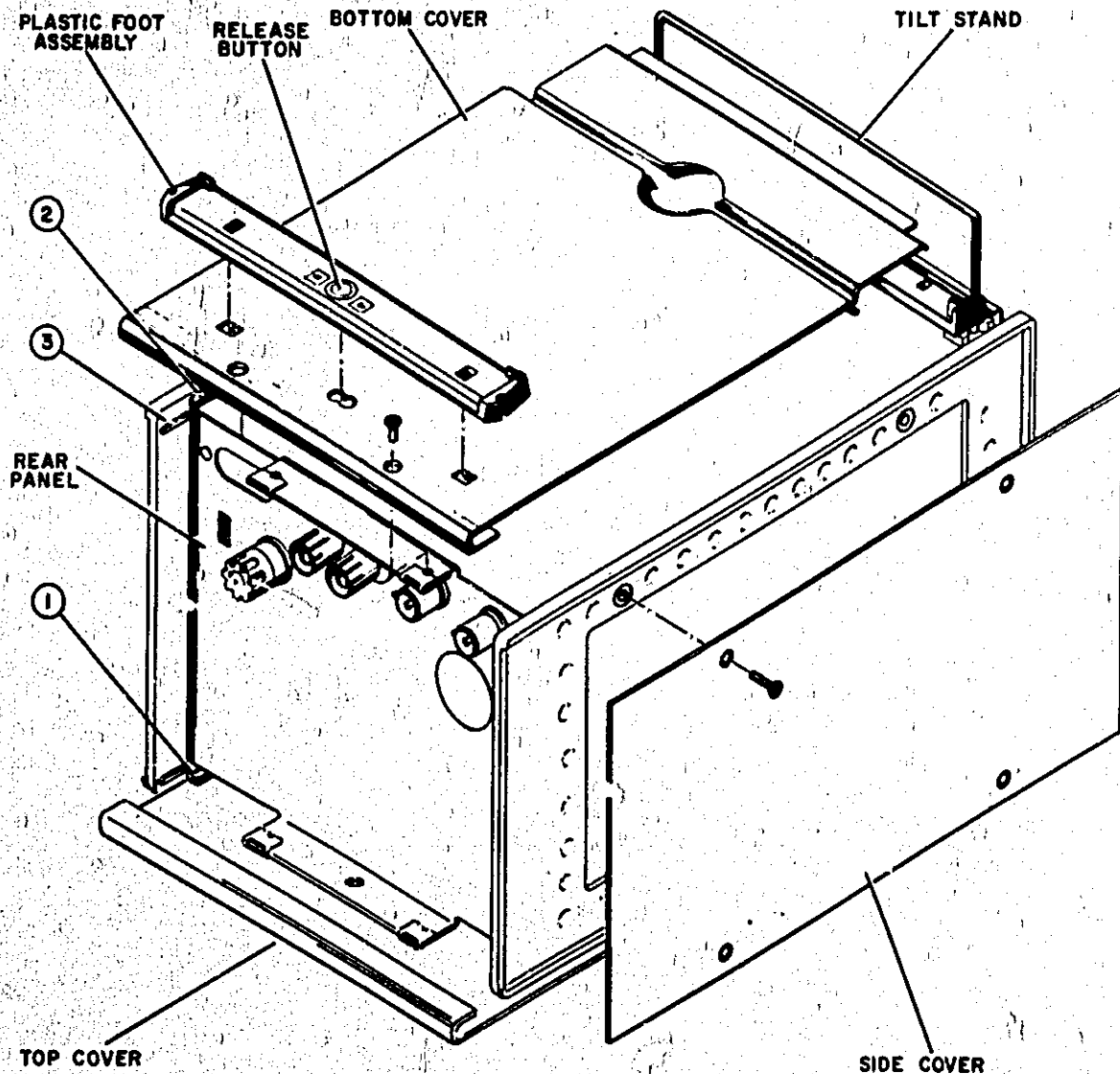

Figure 5-1. Cover Removal

b. Grasp the cover from the rear, slide it back 1/2 inch, then tilt forward edge of the cover upward and lift the cover from the instrument.

5-14. TOP COVER REPLACEMENT.

a. Rest the cover flat on the cast guides projecting inward near the top of each side frame (see ①, Figure 5-1).

b. Slide the cover forward allowing its forward edge to enter the groove in the front panel.

c. Replace the two cover retaining screws.

5-15. BOTTOM COVER REMOVAL.

a. Set the tilt stand as shown in Figure 5-1.

b. Remove the two retaining screws at the rear of the cover.

c. Slide the cover rearward far enough to free its forward edge from the front foot assembly.

d. Tilt the forward edge of the cover upward and lift the cover from the instrument.

5-16. BOTTOM COVER REPLACEMENT.

a. Set the tilt stand as shown in Figure 5-1.

b. Rest the bottom cover flat on the cast guides projecting inward near the bottom of each side frame (see ②, Figure 5-1).

c. Slide the cover forward on the guides so that the formed portion at the rear of the cover slides over the two short projections at the rear corner of each side frame (see ③, Figure 5-1).

d. Replace the two retaining screws and the rear foot assembly.

5-17. POWER SUPPLY ADJUSTMENT.

Procedure

CAUTION

Adjustment of the Power Supply voltage affects instrument accuracy. If voltages are in tolerance, do not adjust.

Paragraphs 5-18 to 5-21

- a. Connect a DC voltmeter between pin W, XA2 and ground.
- b. Adjust A2R36 for -18.00 ± 0.02 VDC.

5-18. OSCILLATOR FREQUENCY ADJUSTMENT.

Procedure

- a. Connect 100 or 200 ohm thermistor mount to power meter.

Note

Oscillator frequency will vary approximately ± 0.1 kHz depending on thermistor mount terminating impedance. For the following adjustments, terminate the thermistor mount with a standard 50 ohm termination. Balanced and waveguide mounts do not require termination.

- b. Set power meter controls as follows:
 POWER ON
 CALIB FACTOR 100%
 MOUNT RES to correspond to resistance and type of thermistor mount used.
- c. Connect an electronic counter between the positive side of capacitor A1C18 and ground.
- d. Perform the following adjustment that corresponds to the resistance and type of thermistor mount connected to power meter.

- (1) 100 OHM THERMISTOR MOUNT. Use a decade capacitance to select a value for A1C3 (1000 pF maximum) that causes an oscillation frequency of 10.00 ± 0.05 kHz. Install selected value of A1C3.
- (2) 200 OHM THERMISTOR MOUNT. Adjust A1L2 for an oscillation frequency of 10.00 ± 0.01 kHz.

5-19. OSCILLATOR TANK CIRCUIT TUNING.

Note

Adjust only if frequency determining components are replaced.

Procedure

- a. Connect 100 or 200 ohm thermistor mount to power meter.
- b. Set power meter MOUNT RES switch to correspond to resistance and type of thermistor mount used.
- c. Disconnect negative side of capacitor A1C18 from power meter assembly board A1.
- d. Connect 200CD Oscillator output and electronic counter input between negative lead of capacitor A1C18 and ground.
- e. Connect oscilloscope probe between point of circuit from which A1C18 was disconnected and ground.
- f. Set vertical sensitivity of oscilloscope to 0.2V/division.
- g. Adjust 200CD Oscillator amplitude to obtain a sine wave display on the oscilloscope.
- h. Using a decade capacitance, select a value for A1C22 that causes a peak display on the oscilloscope at a frequency of 10.00 ± 0.02 kHz. Range of A1C22: 300 pF to 6000 pF.
- i. Install selected value of A1C22 and reconnect negative lead of A1C18 to assembly board A1.

5-20. ZERO AND VERNIER CONTROL ADJUSTMENT.

Procedure

- a. Perform steps a through c of ZERO CARRY-OVER performance test, Table 5-2.
- b. Rotate 431C Power Meter RANGE switch clockwise through remaining ranges. Adjust A1R37 to hold DC voltmeter reading within 0.00 ± 0.01 VDC on each range.

5-21. COARSE NULL ADJUSTMENT.

Procedure

100 OHM THERMISTOR MOUNT

- a. Connect 100 ohm thermistor mount to power meter.
- b. Connect oscilloscope or AC voltmeter from A1R55 to ground.
- c. Set power meter controls as follows:
 POWER ON
 RANGE01 mW
 CALIB FACTOR 100%
 MOUNT RES 100 Ω
- d. Adjust ZERO control for an on-scale meter reading.
- e. Mechanically center NULL capacitor, C1.
- f. Adjust A1L1 for a voltage null at A1R55. Fine adjust NULL capacitor C1 for less than 1.5 volts peak to peak.

- g. Set power meter RANGE switch to NULL, and fine adjust NULL capacitor C1 for a zero power meter reading. C1 should remain near mechanical center of range $\pm 10^\circ$.
- h. Rotate power meter RANGE switch clockwise through remaining ranges. Voltage null at A1R55 should remain less than 1.5 volts peak to peak.

200 OHM THERMISTOR MOUNT

- i. Connect 200 ohm thermistor mount to power meter.
- j. Connect oscilloscope or AC voltmeter from A1R55 to ground.
- k. Set power meter controls as follows:
 POWER ON
 RANGE01 mW
 CALIB FACTOR 100%
 MOUNT RES 200 Ω
- m. Adjust ZERO control for an on-scale meter reading.
- n. Mechanically center NULL capacitor C1.
- o. Select capacitor A1C1 (refer to Table 5-3) for a voltage null at A1R55. Fine adjust NULL capacitor C1 for less than 1.5 volts peak to peak.
- p. Set power meter RANGE switch to NULL, and fine adjust NULL capacitor C1 for a zero power meter reading. C1 should remain near mechanical center of range $\pm 45^\circ$.

Note

If a null cannot be obtained, do not select A1C1 for a value greater than 1000 pF. Increase A1C2 in 50 pF steps, and repeat steps through g until limits are met.

5-22. FULL SCALE ACCURACY ADJUSTMENTS.

Note

It may be necessary to adjust the -18 volt supply slightly to get all ranges within tolerance. Exercise caution when adjusting the -18 volt supply, as the adjustment of the supply affects instrument accuracy. Refer to Paragraph 5-17 for supply tolerance.

Procedure.

- a. Measure from M1 negative terminal to ground using the 3440A/3443A DVM.
- b. Measure meter circuit current using a HP 428B clip-on DC Milliammeter.
- c. Adjust ZERO control for 1 mA through the meter circuit.
- d. Maintain 1 mA through the meter circuitry, and adjust A2R34 for DVM reading of 1.248 ±.004 VDC.
- e. Connect equipment as shown in Figure 3-9.
- f. Set 8402B Calibrator controls as follows:
FUNCTION CURRENT OFF
MOUNT RESISTANCE to correspond with resistance and type of thermistor mount used.
- g. Set 431C Power Meter as follows:
POWER ON
CALIB FACTOR 100%
MOUNT RES to correspond with resistance and type of thermistor mount used.
- h. Null and zero-set the power meter (refer to Turn On and Nulling Procedure, Figure 3-8).
- i. 100 OHM THERMISTOR MOUNT. Set calibrator and power meter controls and make corresponding adjustment as listed below.*

- j. 100 OHM THERMISTOR MOUNT. Set calibrator and power meter controls and make corresponding adjustments as listed below.*

Range (mW)	8402B Calibrator	431C Power Meter	
	Function	Adjust	Reading
.01	CURRENT OFF	ZERO	0.0
.01	CALIBRATE	A2R1	.01 mW
.03	CURRENT OFF	ZERO	0.0
.03	CALIBRATE	A2R2	.03 mW
.1	CURRENT OFF	ZERO	0.0
.1	CALIBRATE	A2R3	.1 mW
.3	CURRENT OFF	ZERO	0.0
.3	CALIBRATE	A2R4	.3 mW
1	CURRENT OFF	ZERO	0.0
1	CALIBRATE	A2R5	1.0 mW
3	CURRENT OFF	ZERO	0.0
3	CALIBRATE	A2R6	3.0 mW
10	CURRENT OFF	ZERO	0.0
10	CALIBRATE	A2R7	10.0 mW

* (Refer to Para. 3-27 for thermo-electric correction on lower ranges.)

Table 5-3. Circuit Requirements for Factory Selected Parts

Part Ref. Desig.	Circuit Requirements
R25	Full scale deflection of meter M1 when 1 mA of DC flows through the combination of the meter and R25.
A1R6	Selected to set 10 KHz Amplifier attenuator accuracy over all bands.
A1R7	Balance of RF detection bridge when using a 100 ohm thermistor mount with no microwave power applied.
A1R9	Balance of RF detection bridge when using a 200 ohm thermistor mount with no microwave power applied.
A1R36	Sets coarse full scale accuracy on all ranges with A1R37 centered.
A1C1	NULL capacitor, C1, set near mid-range for null when using a 200 ohm thermistor mount. Refer to Paragraph 5-21.
A1C2	NULL capacitor, C1, set near mid-range for null when using a 100 ohm thermistor mount. Refer to Paragraph 5-21.
A1C3	10 kHz output of oscillator amplifier, A1Q4-Q7, when using a 100 ohm thermistor mount. Refer to Paragraph 5-18.
A1C4-5	Must be within ±1% of same value. Set 10kHz Oscillator Frequency with A1L2 centered.
A1C22	Frequency of 10 kHz for A1T5/A1C15 tuned circuit combination. Refer to Paragraph 5-19.

Range (mW)	8402B Calibrator	431C Power Meter	
	Function	Adjust	Reading
.01	CURRENT OFF	ZERO	0.0
.01	CALIBRATE	A2R14	.01 mW
.03	CURRENT OFF	ZERO	0.0
.03	CALIBRATE	A2R13	.03 mW
.1	CURRENT OFF	ZERO	0.0
.1	CALIBRATE	A2R12	.1 mW
.3	CURRENT OFF	ZERO	0.0
.3	CALIBRATE	A2R11	.3 mW
1	CURRENT OFF	ZERO	0.0
1	CALIBRATE	A2R10	1.0 mW
3	CURRENT OFF	ZERO	0.0
3	CALIBRATE	A2R9	3.0 mW
10	CURRENT OFF	ZERO	0.0
10	CALIBRATE	A2R8	10.0 mW

5-23. TROUBLESHOOTING.

5-24. Refer to Tables 5-7 through 5-21 for detailed circuit troubleshooting. Check the fuse. Make a visual inspection for burned, loose, or dirty components and connections. Often a visual check of the instrument will reveal sources of malfunction with no further troubleshooting. Do not adjust any internal circuit controls before a general idea of the trouble is formulated.

5-25. The first step in troubleshooting the 431C is to isolate the trouble to either the thermistor mount and thermistor-mount cable combination or the power meter. The operating note furnished with hp thermistor mounts gives a procedure to check the thermistor mount. This procedure will indicate any deficient performance of the mount. An ohmmeter continuity check can be used to determine if the thermistor mount cable or cable connectors are defective.

5-26. TROUBLE ISOLATION. Circuits in the 431C can be divided into five basic functional units as follows: 1) RF detection bridge and 10 kHz oscillator-amplifier (A1Q4-A1Q7), 2) compensation and metering bridge, 10 kHz amplifier (A1Q1-A1Q3) and synchronous detector, 3) differential amplifier (A1Q8-A1Q9) and feedback current generator (A1Q10), 4) feedback current-squared generator (A1Q11) and metering circuits, and 5) power supply.

5-27. The procedure in Table 5-4 employs front panel controls for isolation of trouble to basic circuits. Tables 5-7 through 5-12 employ internal circuit indications for more detailed malfunction analysis.

5-28. The following assumptions are made throughout the front panel trouble isolation procedure: 1) the thermistor mount and thermistor-mount cable combination is working properly, 2) transformers in the detection

Table 5-4. Front Panel Trouble Isolation

Step	Instructions	Indication	Action or Trouble Circuit
1.	a. Connect thermistor mount b. Set RANGE to .01 mW c. Set POWER to ON d. Adjust ZERO for zero meter reading, if possible e. Rotate RANGE from .01 through 10 mW	No meter reading	Proceed with step 2
		Meter reads below low scale limit or meter reads above high scale limit	Proceed with step 3
2.	a. Set RANGE to 10 mW b. Apply RF power to thermistor mount c. Decrease RANGE from 10 mW until reading is obtained	No meter reading	Proceed with step 3
		Any meter reading	a. Perform ACCURACY performance test, Figure 5-2. Particular range inaccuracy: check first for improper range resistance selected by RANGE switch (A1S2). All range inaccuracy: 10 kHz amplifier (A1Q1-A1Q3) and feedback current generator (A1Q10) combination or power supply. b. Proceed with step 3.
3.	a. Remove RF power from thermistor mount b. Set RANGE to NULL c. Adjust NULL screwdriver adjustment	Meter reading that changes with NULL adjustment	Proceed with step 4
		Meter reading that does not change with NULL adjustment	Compensation and metering bridge, 10 kHz amplifier (A1Q1-A1Q3) and synchronous detector combination
		No meter reading	RF detection bridge, and 10 kHz oscillator-amplifier (A1Q4-A1Q7) combination Power supply
4.	a. Set RANGE to .01 mW b. Adjust ZERO for zero meter reading c. Rotate RANGE from .01 through 10 mW	Zero	Feedback current-squared generator (A1Q11) and metering circuits
		No zero	Differential amplifier (A1Q8-A1Q9) and feedback current generator (A1Q10) combination
		Zero does not carry-over within specifications	Differential amplifier (A1Q8-A1Q9) and feedback current-squared generator (A1Q11) combination

bridge, metering bridge and synchronous detector have not failed, and 3) only one basic functional circuit has failed.

5-29. Front panel trouble isolation is intended only to suggest the most probable functional circuit failure and to give a general direction in which to look before starting a detailed troubleshooting procedure.

5-30. It is important that the procedures listed in Table 5-4 be performed in the order listed. Each step forms the basis on which the indications of a subsequent step are analyzed.

5-31. DETAILED TROUBLESHOOTING. To assist detailed troubleshooting, normal-operation waveforms are given in Figures 7-3 and 7-8. Locations of test points and components are given in Figures 7-2, 7-4, and 7-6. In addition, normal-operation voltages relative to chassis ground are provided on the schematic diagrams for the collector, base and emitter of every transistor in the instrument. Waveforms and voltage measurements were made with a thermistor mount connected, and the instrument nulled, according to instructions given in Figure 3-8. The first detailed troubleshooting checks should be performed in the following order: 1) check for power supply output voltages of +1.3, -18, and -25 VDC, 2) check at test point 6 to ensure that the 10 kHz oscillator - amplifier, A1Q4-A1Q7, has the proper output waveform, 3) check at test point 2 for correct output of the 10 kHz amplifier, A1Q1-A1Q3. For signal tracing through the amplifier stages, capacitor A1C10 can be disconnected from A1L1 and used as a means to inject a 10 kHz test signal to the input of the first 10 kHz amplifier, A1Q1.

5-32. COMPONENT TROUBLE ISOLATION. The following procedures and data are given to aid in determining whether a transistor is operational. Tests are given for both in-circuit and out-of-circuit transistors and should be useful in determining whether a particular functional circuit trouble is due to a faulty transistor or an associated component.

5-33. IN-CIRCUIT TESTING. The common causes of transistor failures are internal short- and open-circuits. In transistor circuit testing the most important consideration is the transistor base-emitter junction. Like the control grid of a vacuum tube, this is the operational control point in the transistor. This junction is essentially a solid-state diode. For the transistor to conduct, the diode must conduct; that is, the diode must be forward biased. As with diodes, the forward bias polarity is determined by the materials forming the junction. Use the transistor symbol on the schematic diagram to determine the bias polarity required to forward-bias the base-emitter junction. The A part of Figure 5-2 shows transistor symbols with terminals labeled. The emitter arrow points toward the type N material. The other two columns of the illustration compare the biasing required to cause conduction and cut-off in transistors and vacuum tubes. If the transistor base-emitter diode (junction) is forward-biased, the transistor conducts. If the diode is heavily forward-biased, the transistor saturates. However, if the base-emitter diode is reverse biased, the transistor is cut off (no conduction). The voltage drop across a forward-biased emitter-base diode varies with transistor collector current. For

example, a germanium transistor has a typical forward bias, base-emitter voltage of 0.2 - 0.3 volts when collector current is 1 - 10 mA, and 0.4 - 0.5 volts when collector current is 10 - 100 mA. In contrast, forward-bias voltage for silicon transistors is about twice that for germanium types: about 0.5 - 0.6 volts when collector current is low, and about 0.8 - 0.9 volts when collector current is high.

5-34. Figure 5-2, part B, shows simplified versions of the three basic transistor circuits and gives the operating characteristics of each. When examining a transistor stage, first determine if the emitter-base diode is biased for conduction (forward-biased) by measuring the voltage difference between emitter and base. When using an electronic voltmeter, do not measure directly between emitter and base since there may be sufficient loop current between the voltmeter leads to damage the transistor. Instead, measure each voltage separately with respect to a voltage common point (e.g., chassis). If the emitter-base diode is forward biased, check for amplifier action by shorting base to emitter while observing collector voltage. The short circuit eliminates base-emitter bias and should cause the transistor to stop conducting (cut off). Collector voltage should then shift to near the supply voltage. Any difference is due to leakage current through the transistor and, in general, the smaller this current, the better the transistor. If collector voltage does not change the transistor has either an emitter-collector short circuit or emitter-base open circuit.

5-35. OUT-OF-CIRCUIT TESTING. Remove the transistor from the circuit and use an ohmmeter to measure internal resistance. Refer to Table 5-5 for measurement data.

Table 5-5. Out-of-Circuit Transistor Resistance Measurements

Transistor Type		Connect Ohmmeter		Measure Resistance (ohms)
		Pos. lead to	Neg. lead to	
PNP Germanium	Small Signal	emitter	base*	200-500
		emitter	collector	10k-100k
	Power	emitter	base*	30 - 50
		emitter	collector	several hundred
NPN Silicon	Small Signal	base	emitter	1 k - 3 k
		collector	emitter	very high (might read open)
	Power	base	emitter	200-1000
		collector	emitter	high, often greater than 1M

*To test for transistor action, add collector-base short. Measured resistance should decrease.

A. TRANSISTOR BIASING			
DEVICE	SYMBOL	CUT OFF	CONDUCTING
VACUUM TUBE			
N P N TRANSISTOR			
P N P TRANSISTOR			

B. AMPLIFIER CHARACTERISTICS			
CHARACTERISTIC	COMMON BASE	COMMON EMITTER	COMMON COLLECTOR
INPUT Z	30-50 Ω	500-1500 Ω	20-500K Ω
OUTPUT Z	300-500K Ω	30-50K Ω	50-1000 Ω
VOLTAGE GAIN	500-1500	300-1000	< 1
CURRENT GAIN	< 1	25-50	25-50
POWER GAIN	20-30 db	25-40 db	10-20 db

Figure 5-2. Transistor Biasing and Operating Characteristics

CAUTION

Most ohmmeters can supply enough current or voltage to damage a transistor. Before using an ohmmeter to measure transistor forward or reverse resistance, check its open-circuit voltage and short-circuit current output **ON THE RANGE TO BE USED**. Open-circuit voltage must not exceed 1.5 volts and short-circuit current must be less than 3 mA.

Table 5-6. Safe Ohmmeter Range for Transistor Resistance Measurements

Ohmmeter	Safe Range(s)	Open Ckt Voltage	Short Ckt Current	Lead	
				Color	Polarity
hp 412A hp 427A	R x 1 k R x 10 k R x 100 k R x 1M R x 10M	1.0V 1.0V 1.0V 1.0V 1.0V	1 mA 100 μA 10 μA 1 μA 0.1 μA	Red Blk	+ -
hp 410C	R x 1 k R x 10 k R x 100 k R x 1M R x 10M	1.3V 1.3V 1.3V 1.3V 1.3V	0.57 mA 57 μA 5.7 μA 0.5 μA 0.05 μA	Red Blk	+ -
hp 410B	R x 100 R x 1 k R x 10 k R x 100 k R x 1M	1.1V 1.1V 1.1V 1.1V 1.1V	1.1 mA 110 μA 11 μA 1.1 μA 0.11 μA	Blk Red	+ -
Simpson 260	R x 100	1.5V	1 mA	Red Blk	+ -
Simpson 269	R x 1 k	1.5V	0.82 mA	Blk Red	+ -
Triplett 630	R x 100 R x 1 k	1.5V 1.5V	3.25 mA 325 μA	Varies with Serial Number	
Triplett 310	R x 10 R x 100	1.5V 1.5V	750 μA 75 μA		

Table 5-7. Meter Noise Troubleshooting

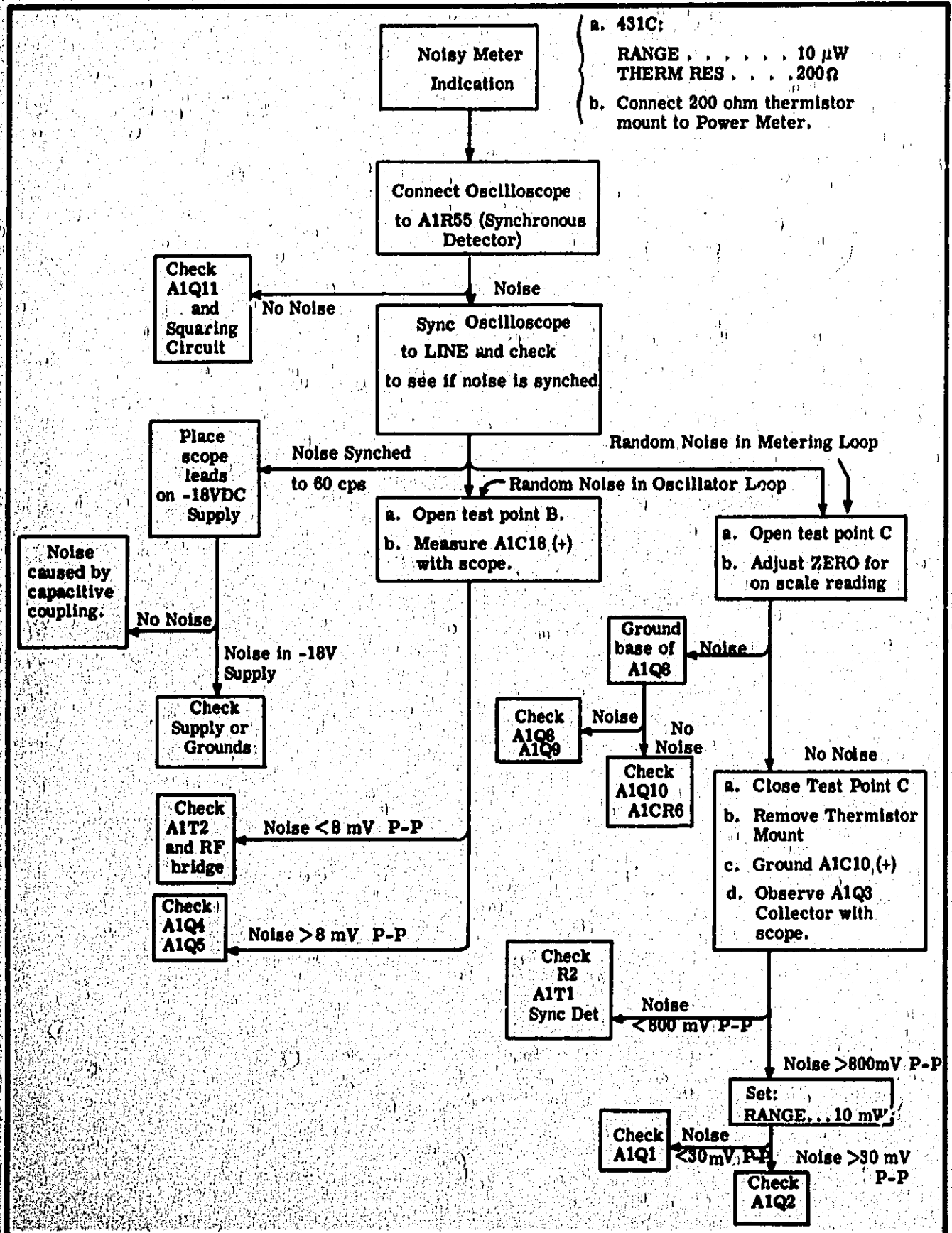

Table 5-8. Metering Loop Troubleshooting (1 of 2)

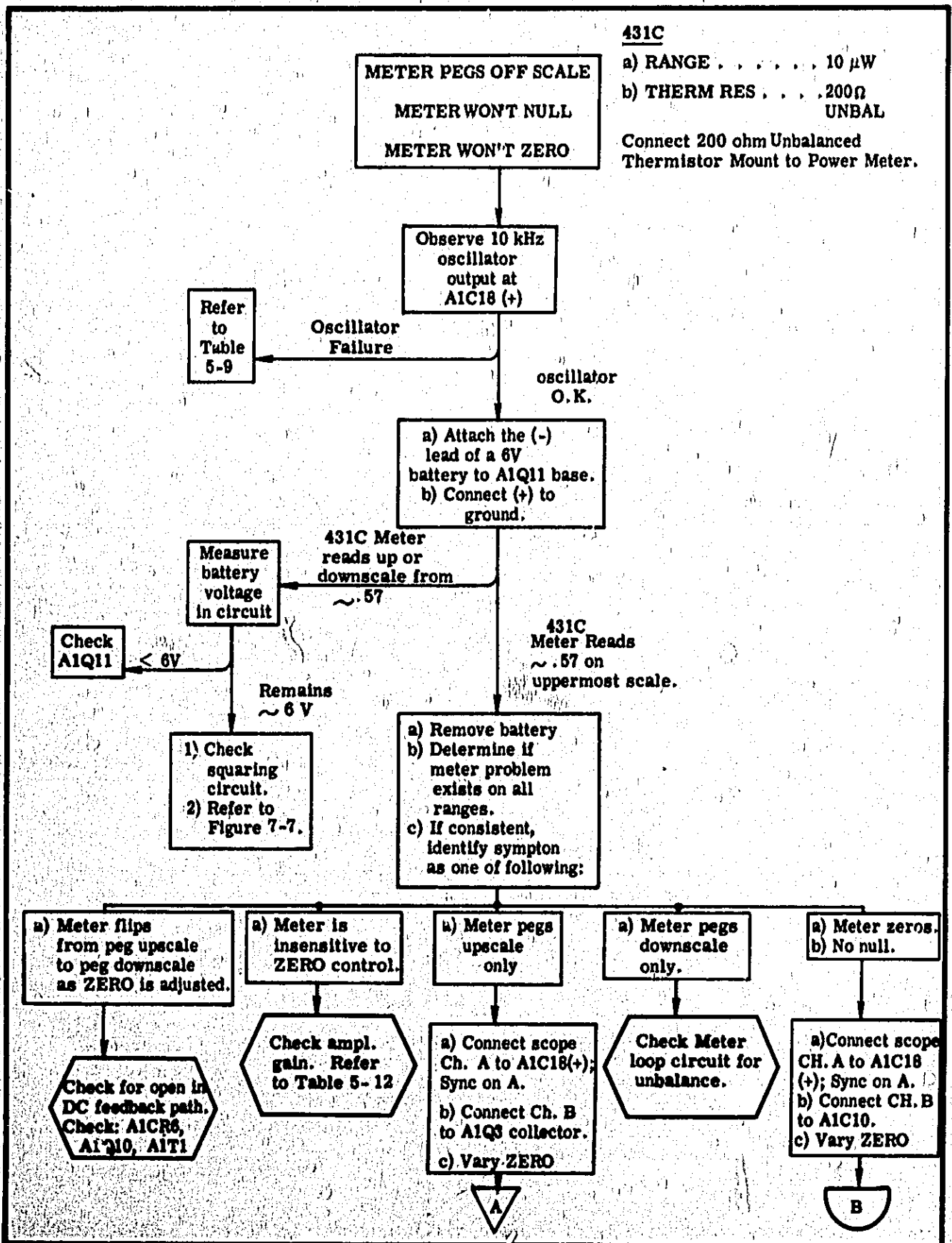

Table 5-8. Metering Loop Troubleshooting (2 of 2)

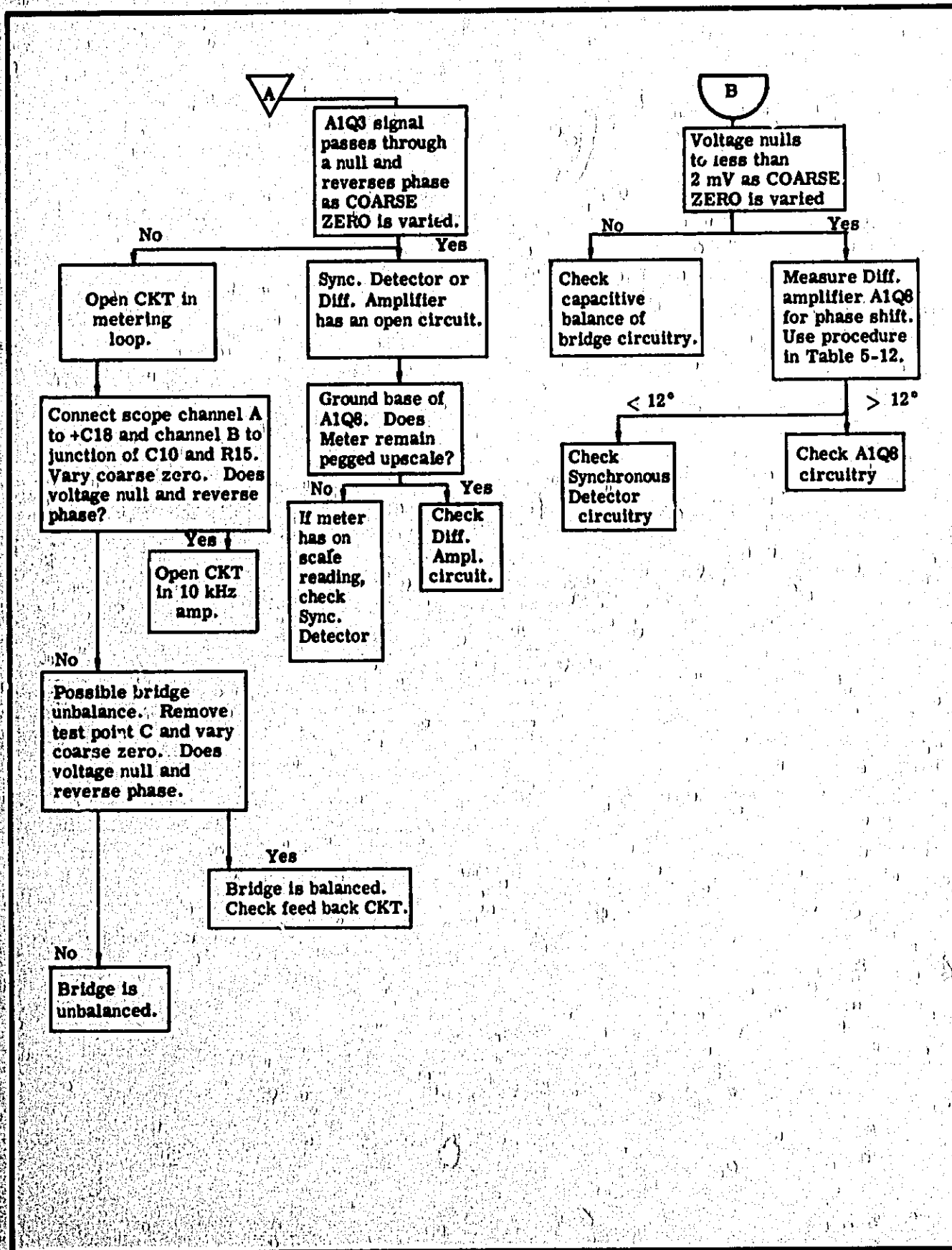
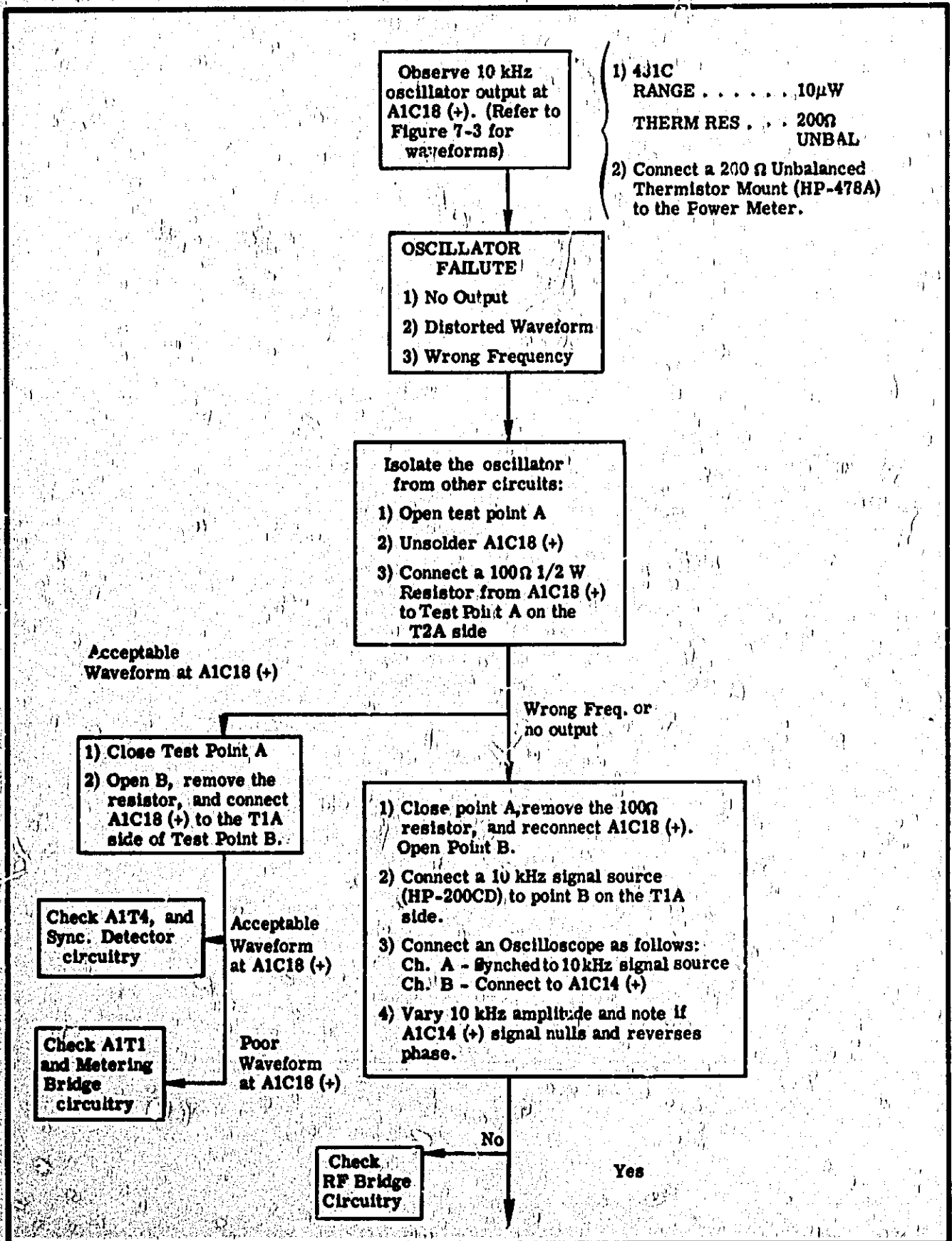

Table 5-9. 10 kHz Oscillator Troubleshooting (1 of 2)



- 1) 431C RANGE 10μW
- THERM RES 200Ω UNBAL
- 2) Connect a 200 Ω Unbalanced Thermistor Mount (HP-478A) to the Power Meter.

Table 5-9. 10 kHz Oscillator Troubleshooting (2 of 2)

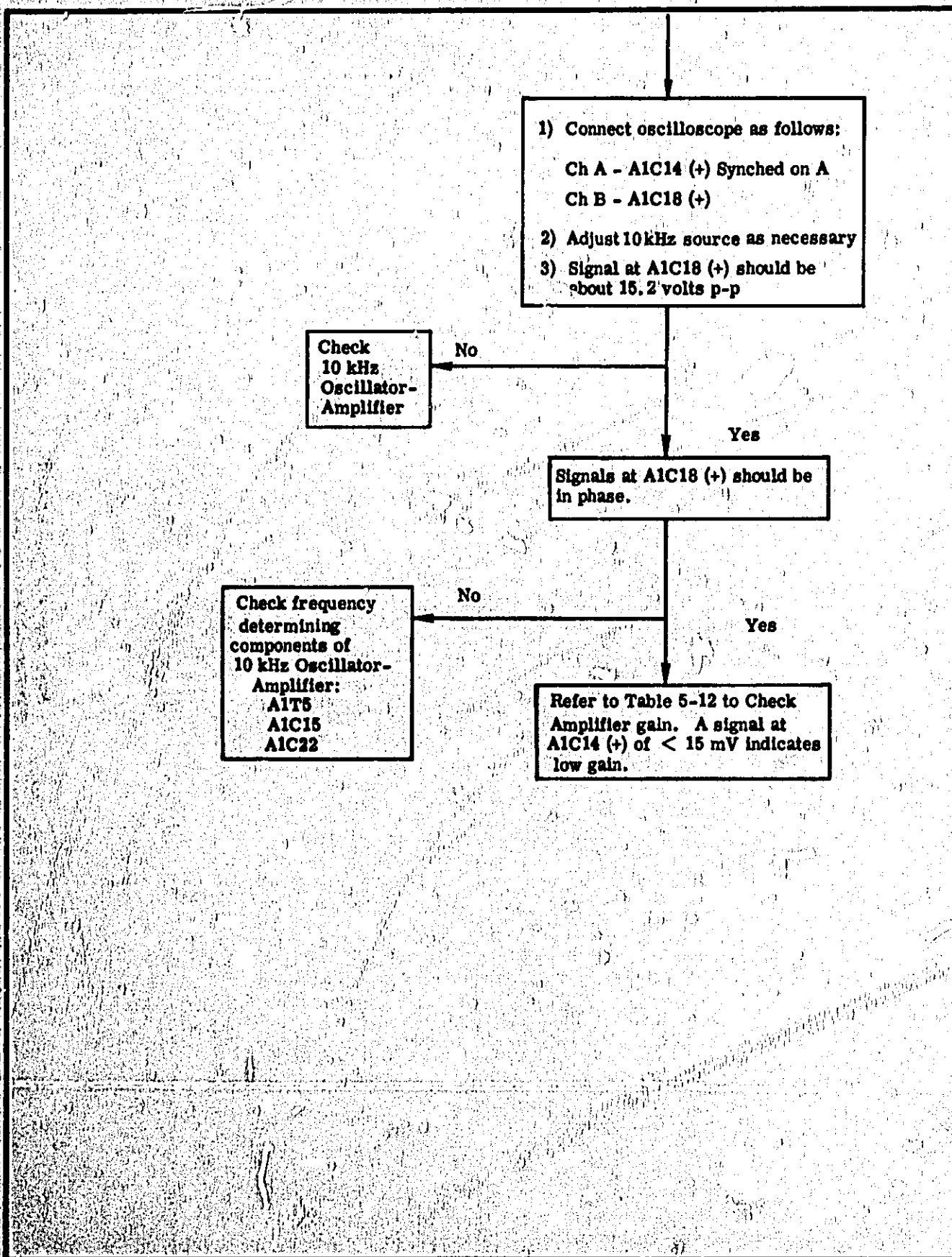

Table 5-10. Meter Accuracy Troubleshooting

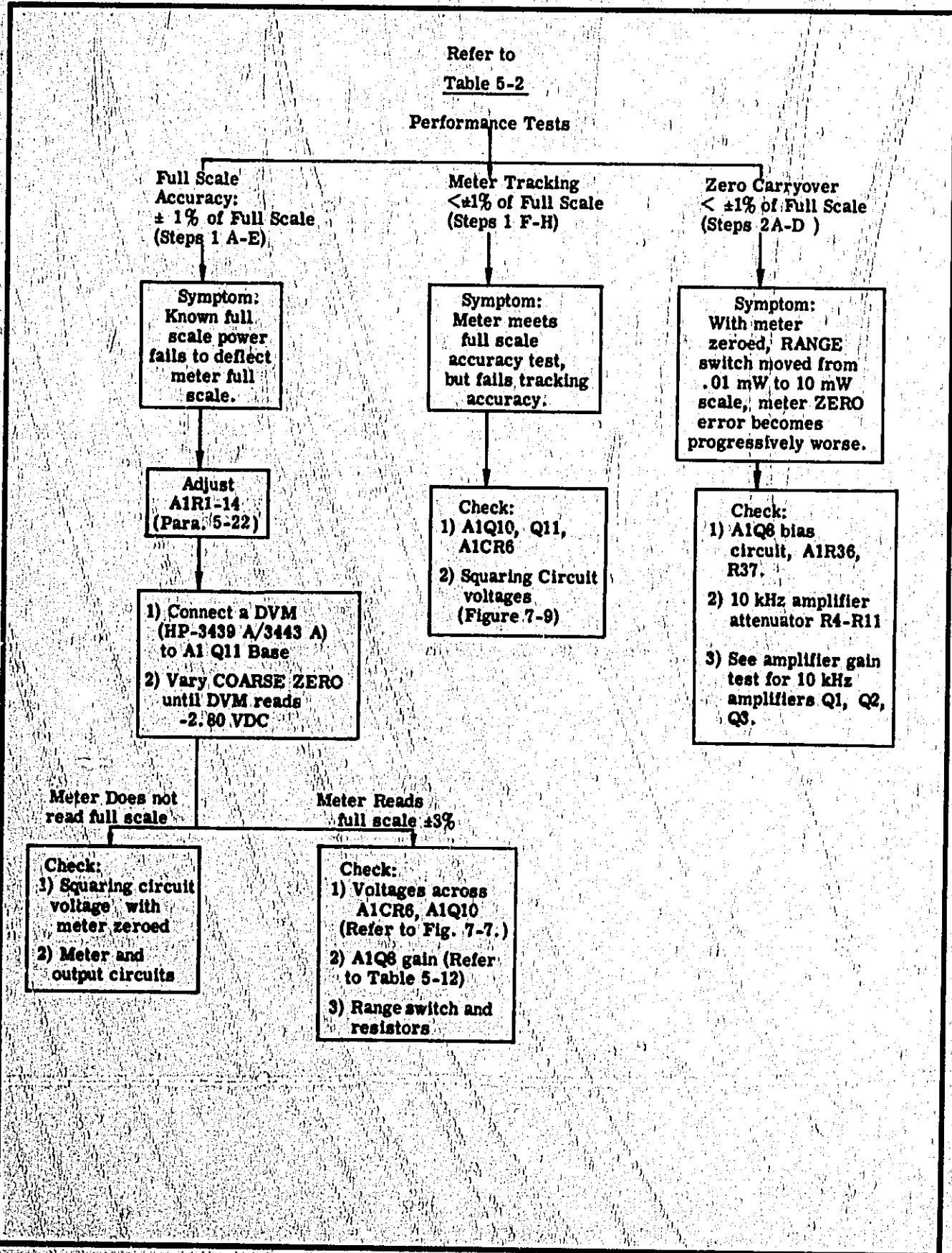

Table 5-11. Power Supply Troubleshooting

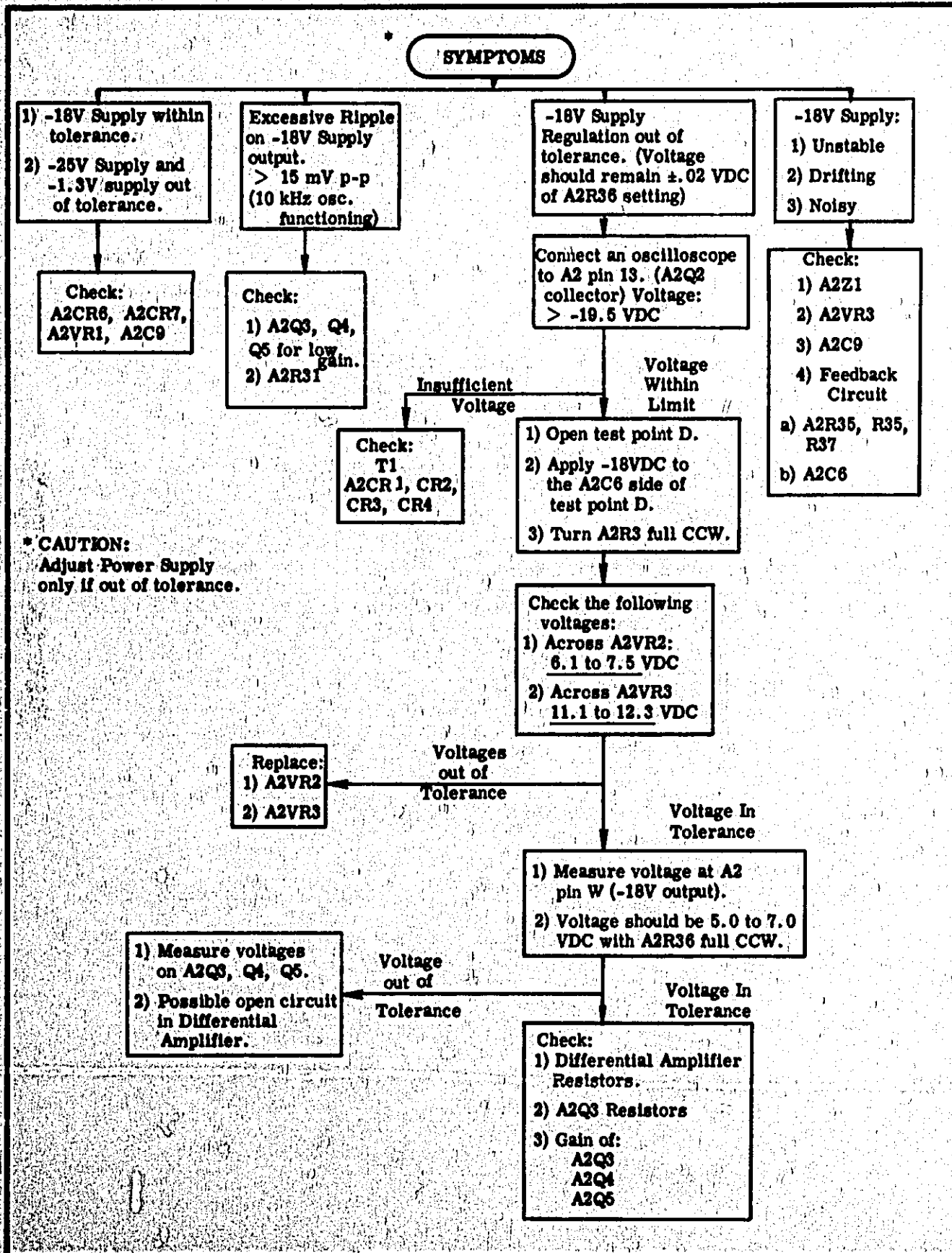

Table 5-12. 10 kHz Amplifier Troubleshooting

NOTE

The following tests gain of the 10 kHz amplifier circuits.

1. Refer to the schematic diagram, Figure 7-5, and 7-7 to perform the amplifier gain test.

2. Use the following test equipment:

Wide-Range Oscillator HP-200CD

Attenuator HP-355D

Oscilloscope Refer to Table 5-1

3. Proceed as follows:

a. Open test point C by removing the jumper.

b. Ground the (+) side of A1C18.

c. Disconnect the bridge side of A1C10.

d. Disconnect the collector of A1Q3, and insert a 5110 ohm resistor from the collector to the junction of A1R23 and A1C13.

e. Attach the 355D Attenuator to the output of the oscillator. Set the attenuation to 10 dB.

f. Connect the oscilloscope to A1Q3 collector.

g. Set the 431C RANGE to 10 mW.

h. Set the oscillator output control to 50. Connect the attenuator output to the disconnected side of A1C10.

i. Adjust oscillator output amplitude until A1Q3 collector voltage equals 10 volts p-p, or until the signal just begins to clip, whichever occurs first.

j. Measure the voltage at the base of A1Q1, and at the base of A1Q3. Both voltages should be approximately 80 mV p-p.

k. To check amplifier gain on other 431C ranges, move the RANGE switch and attenuator setting as in the table below:

(Maintain the oscillator level as set in step i. above.)

431C RANGE	355D Atten.	A1Q3-Coll.*	A1Q3-Base*
10 mW	10	9.6 Vp-p ±25% ↓	80 mV p-p ±25% ↓
3 mW	20		
1 mW	30		
.3 mW	40		
.1 mW	50		
.03 mW	60		
.01 mW	70		

j. Phase Shift Test:

1. Use the test setup described in Step a. through j. above.

2. Connect a dual trace oscilloscope as follows:

Channel A .. SYNC on oscillator output

Channel B .. Observe A1Q3 Collector

3. Compare the phase of the signal from the oscillator with the signal at A1Q3 collector. Phase shift should not exceed 12 degrees.

SECTION VI REPLACEABLE PARTS

6-1. INTRODUCTION.

6-2. This section contains information for ordering replacement parts. Table 6-1 lists parts in alpha-numerical order of their reference designators and indicates the description and hp stock number of each part, together with any applicable notes. Miscellaneous parts are listed at the end of Table 6-1. Table 6-2 lists parts in alpha-numerical order of their hp stock number and provides the following information on each part:

- a. Description.
- b. Manufacturer of the part in a five-digit code; see list of manufacturers in Table 6-3.
- c. Manufacturer's part number.
- d. Total quantity used (TQ column).

6-3. ORDERING INFORMATION.

6-4. To obtain replacement parts, address order or inquiry to your local Hewlett-Packard Field Office (see list at rear of this manual for addresses). Identify parts by their Hewlett-Packard stock numbers.

6-5. To obtain a part that is not listed, include:

- a. Instrument model number.
- b. Instrument serial number.
- c. Description of the part.
- d. Function and location of the part.

REFERENCE DESIGNATORS

<p>A = assembly S = motor BT = battery C = capacitor CP = coupler CR = diode DL = delay line DS = device signaling (lamp) E = misc electronic part</p>	<p>F = fuse FL = Filter J = jack K = relay L = inductor LS = loud speaker M = meter MK = microphone MP = mechanical part</p>	<p>P = plug Q = transistor R = resistor RT = thermistor S = switch T = transformer TB = terminal board TP = test point U = integrated circuit</p>	<p>V = vacuum tube, neon bulb, photocell, etc. VR = voltage regulator W = cable X = socket Y = crystal Z = tuned cavity, network</p>
---	---	--	--

ABBREVIATIONS

<p>A = amperes AFC = automatic frequency control AMPL = amplifier BFO = beat frequency oscillator BE CU = beryllium copper BH = binder head BP = bandpass BR = brass BWO = backward wave oscillator CCW = counterclockwise CER = ceramic CMO = cabinet mount only COEF = coefficient COM = common COMP = composition COMPL = complete CONN = connector CP = cadmium plate CRT = cathode-ray tube CW = clockwise DEPC = deposited carbon DR = drive ELECT = electrolytic ENCAP = encapsulated EXT = external F = farads FH = flat head FIL H = Filister head FXD = fixed G = giga (10⁹) GE = germanium GL = glass GRD = ground(ed)</p>	<p>H = henries HDW = hardware HEX = hexagonal HG = mercury HR = hour(s) Hz = Hertz IF = intermediate freq IMPG = impregnated INCD = incandescent INCL = include(s) INS = insulation(ed) INT = internal K = kilo = 1000 LH = left hand LIN = linear taper LK WASH = lock washer LOG = logarithmic taper LPF = low pass filter M = milli = 10⁻³ MEG = meg = 10⁶ MET FLM = metal film MET OX = metallic oxide MFR = manufacturer MHz = mega Hertz MINAT = miniature MOM = momentary MOS = metallized substrate MTG = mounting MY = "mylar" N = nano (10⁻⁹) N/C = normally closed NE = neon NI PL = nickel plate</p>	<p>N/O = normally open NOM = nominal NPO = negative positive zero (zero temperature coefficient) NPN = negative-positive-negative NRFR = not recommended for field replacement NSR = not separately replaceable OBD = order by description OH = oval head OX = oxide P = peak PC = printed circuit PF = picofarads = 10⁻¹² farads PH BRZ = phosphor bronze PHL = Phillips PIV = peak inverse voltage PNP = positive-negative-positive P/O = part of POLY = polystyrene PORC = porcelain POS = position(s) POT = potentiometer PP = peak-to-peak PT = point PWV = peak working voltage RECT = rectifier RF = radio frequency RH = round head or right hand</p>	<p>RMO = rack mount only RMS = root-mean square RWV = reverse working voltage S-B = slow-blow SCR = screw SE = selenium SECT = section(s) SEMICON = semiconductor SI = silicon SIL = silver SL = slide SPG = spring SPL = special SST = Stainless steel SR = split ring STL = steel TA = tantalum TD = time delay TGL = toggle THD = thread TI = titanium TOL = tolerance TRIM = trimmer TWT = travelling wave tube μ = micro = 10⁻⁶ VAR = variable VDCW = dc working volts W/ = with W = watts WIV = working inverse voltage WW = wirewound W/O = without</p>
--	---	--	--

Table 6-1. Reference Designation Index

Reference Designation	Stock No.	Description #	Note
A1	00431-6018	BOARD ASSY:AMPLIFIER	
A1C1	0140-0198	CIFXD MICA 200PF 5% 300VDCW FACTORY SELECTED PART: TYPICAL VALUE GIVEN	
A1C2	0160-2201	CIFXD MICA 51 PF 5% FACTORY SELECTED PART: TYPICAL VALUE GIVEN	
A1C3	0140-0198	CIFXD MICA 200PF 5% 300VDCW FACTORY SELECTED PART: TYPICAL VALUE GIVEN	
A1C4	0160-0136	CIFXD MICA 2500PF 1% 300VDCW(FACTORY SELECTED PART)	
A1C5	0160-0136	CIFXD MICA 2500PF 1% 300VDCW(FACTORY SELECTED PART)	
A1C6	0180-0116	CIFXD ELECT TA 6.8 UF 10% 35VDCW	
A1C7	0180-0116	CIFXD ELECT TA 6.8 UF 10% 35VDCW	
A1C8	0180-0106	CIFXD ELECT TA 60UF 20% 6VDCW	
A1C9	0170-0069	CIFXD POLY 0.1UF 2% 50VDCW	
A1C10	0160-0174	CIFXD CER 0.47UF +80-2% 25VDCW	
A1C11	0160-0174	CIFXD CER 0.47UF +80-20% 25VDCW	
A1C12	0170-0069	CIFXD POLY 0.1UF 2% 50VDCW	
A1C13	0180-0116	CIFXD ELECT TA 6.8 UF 10% 35VDCW	
A1C14	0180-0116	CIFXD ELECT TA 6.8 UF 10% 35VDCW	
A1C15	0170-0069	CIFXD POLY 0.1UF 2% 50VDCW	
A1C16	0180-0116	CIFXD ELECT TA 6.8 UF 10% 35VDCW	
A1C17	0180-0116	CIFXD ELECT TA 6.8 UF 10% 35VDCW	
A1C18	0180-0049	CIFXD AL ELECT 20UF 50VDCW	
A1C19	0180-0045	CIFXD ELECT 20UF 25VDCW	
A1C20	0180-0045	CIFXD ELECT 20UF 25VDCW	
A1C21	0160-0174	CIFXD CER 0.47UF +80-20% 25VDCW	
A1C22	0140-0159	CIFXD MICA 3000PF 300VDCW	
A1C23		FACTORY SELECTED PART:USED ONLY FOR OPT 23.	
A1CR1	1901-0025	DIODE:JUNCTION:5MA AT 1V 100 PIV	
A1CR2	1910-0016	DIODE:GERMANIUM 100MA AT 0.85V 60PIV	
A1CR3	1910-0016	DIODE:GERMANIUM 100MA AT 0.85V 60PIV	
A1CR4	1910-0016	DIODE:GERMANIUM 100MA AT 0.85V 60PIV	
A1CR5	1910-0016	DIODE:GERMANIUM 100MA AT 0.85V 60PIV	
A1CR6	1901-0450	DIODE:SILICON	
A1CR7	1901-0025	DIODE:JUNCTION:5MA AT 1V 100 PIV	
A1CR8	1901-0025	DIODE:JUNCTION:5MA AT 1V 100 PIV	
A1CR9	1901-0450	DIODE:SILICON	
A1CR10	1901-0450	DIODE:SILICON	
A1CR11	1901-0450	DIODE:SILICON	
A1CR12	1901-0450	DIODE:SILICON	
A1CR13	1901-0450	DIODE:SILICON	
A1CR14	1901-0450	DIODE:SILICON	
A1CR15	1901-0450	DIODE:SILICON	
A1L1	9140-0122	COIL:VAR 2X 9-20 UHY EACH	
A1L2	9140-0122	COIL:VAR 2X 9-20 UHY EACH	
A1L3	9110-0040	INDUCTOR:AUDIO	
A1L4	9110-0040	INDUCTOR:AUDIO	
A1Q1	1853-0020	TRANSISTOR:SILICON PNP	
A1Q2	1854-0071	TRANSISTOR:SILICON NPN 2N3391	
A1Q3	1853-0020	TRANSISTOR:SILICON PNP	

* See list of abbreviations in introduction to this section

Table 6-1. Reference Designation Index (Cont'd)

Reference Designation	Stock No.	Description #	Note
A1Q4	1854-0071	TRANSISTOR SILICON NPN 2N3391	
A1Q5	1853-0020	TRANSISTOR SILICON PNP	
A1Q6	1854-0071	TRANSISTOR SILICON NPN 2N3391	
A1Q7	1853-0020	TRANSISTOR SILICON PNP	
A1Q8	1853-0020	TRANSISTOR SILICON PNP	
A1Q9	1853-0020	TRANSISTOR SILICON PNP	
A1Q10	1854-0071	TRANSISTOR SILICON NPN 2N3391	
A1Q11	1854-0071	TRANSISTOR SILICON NPN 2N3391	
A1R1	0811-0066	RIFXD WW 887 OHM 1% 1/10W	
A1R2	0811-0065	RIFXD WW 511 OHM 1.0% 1/20W	
A1R3	0811-0065	RIFXD WW 511 OHM 1.0% 1/20W	
A1R4	0757-0199	RIFXD MET FLM 21.5K OHM 1% 1/8W	
A1R5	0811-1571	RIFXD WW 189 OHM 0.1% 1/8W	
A1R6	0811-1572	RIFXD WW 255 OHM 0.1% 1/8W	
A1R7	0757-0460	RIFXD MET FLM 61.9K OHM 1% 1/8W FACTORY SELECTED PART, TYPICAL VALUE GIVEN	
A1R8	0811-1645	RIFXD WW 202.1 OHM 0.1% 1/8W	
A1R9	0757-0123	RIFXD MET FLM 34.8K OHM 1% 1/10W FACTORY SELECTED PART, TYPICAL VALUE GIVEN	
A1R10	0811-1566	RIFXD WW 800 OHM 0.1% 1/8W	
A1R11	0757-0417	RIFXD MET FLM 562 OHM 1% 1/8W	
A1R12	0757-1094	RIFXD MET FLM 1.47K OHM 1% 1/8W	
A1R13	0757-0279	RIFXD MET FLM 3.16K OHM 1% 1/8W	
A1R14	0698-0085	RIFXD MET FLM 2.61K OHM 1% 1/8W	
A1R15	0757-0440	RIFXD MET FLM 7.50K OHM 1% 1/8W	
A1R16	0757-0279	RIFXD MET FLM 3.16K OHM 1% 1/8W	
A1R17	0757-0280	RIFXD MET FLM 1.00K OHM 1% 1/8W	
A1R18	0757-0440	RIFXD MET FLM 7.50K OHM 1% 1/8W	
A1R19	0698-3156	RIFXD MET FLM 14.7K OHM 1% 1/8W	
A1R20	0698-3157	RIFXD MET FLM 19.6K OHM 1% 1/8W	
A1R21	0698-3157	RIFXD MET FLM 19.6K OHM 1% 1/8W	
A1R22	0757-0279	RIFXD MET FLM 3.16K OHM 1% 1/8W	
A1R23	0698-3438	RIFXD MET FLM 147 OHM 1% 1/8W	
A1R24	0757-0465	RIFXD MET FLM 100K OHM 1% 1/8W	
A1R25	0698-3452	RIFXD MET FLM 147K OHM 1% 1/8W	
A1R26	0698-3440	RIFXD MET FLM 196 OHM 1% 1/8W	
A1R27	0757-0442	RIFXD MET FLM 10.0K OHM 1% 1/8W	
A1R28	0698-3160	RIFXD MET FLM 31.6K 1% 1/8W	
A1R29	0757-0199	RIFXD MET FLM 21.5K OHM 1% 1/8W	
A1R30	0757-0442	RIFXD MET FLM 10.0K OHM 1% 1/8W	
A1R31	0757-0280	RIFXD MET FLM 1.00K OHM 1% 1/8W	
A1R32	0757-0280	RIFXD MET FLM 1.00K OHM 1% 1/8W	
A1R33	0757-0280	RIFXD MET FLM 1.00K OHM 1% 1/8W	
A1R34	0757-0280	RIFXD MET FLM 1.00K OHM 1% 1/8W	
A1R35	0698-0084	RIFXD MET FLM 2150 OHM 1% 1/8W	
A1R36	0698-3450	RIFXD MET FLM 42.2K OHM 1% 1/8W -FACTORY SELECTED PART.	
A1R37	2100-0144	RIVAR COMP 250K OHM 30% LIN 1/5W	
A1R38	0698-3447	RIFXD MET FLM 422 OHM 1% 1/8W	
A1R39	0757-0417	RIFXD MET FLM 562 OHM 1% 1/8W	
A1R40	0757-0274	RIFXD MET FLM 1.21K OHM 1% 1/8W	
A1R41	0698-3449	RIFXD MET FLM 28.7K OHM 1% 1/8W	

* See list of abbreviations in introduction to this section

Table 6-1. Reference Designation Index (Cont'd)

Reference Designation	Stock No.	Description #	Note
A1R42	0698-4028	RIFXD MET FLM 48.64K OHM 1/2% 1/8W	
A1R43	0698-4029	RIFXD MET FLM 53.39K OHM 1/2% 1/8W	
A1R44	0698-4027	RIFXD MET FLM 64.45K OHM 1/2% 1/8W	
A1R45	0698-4026	RIFXD MET FLM 89.90K OHM 1/2% 1/8W	
A1R46	0698-4025	RIFXD MET FLM 128.5K OHM 1/2% 1/8W	
A1R47	0698-4024	RIFXD MET FLM 259.6K OHM 1/2% 1/8W	
A1R48	0698-4023	RIFXD MET FLM 130.4K OHM 1/2% 1/8W	
A1R49	0698-4034	RIFXD MET FLM 84.32K OHM 1/2% 1/8W	
A1R50	0698-4033	RIFXD MET FLM 62.26K OHM 1/2% 1/8W	
A1R51	0698-4032	RIFXD MET FLM 51.22K OHM 1/2% 1/8W	
A1R52	0698-4031	RIFXD MET FLM 43.25K OHM 1/2% 1/8W	
A1R53	0698-4030	RIFXD MET FLM 40.77K OHM 1/2% 1/8W	
A1R54	0698-4028	RIFXD MET FLM 48.64K OHM 1/2% 1/8W	
A1R55	0698-0082	RIFXD MET FLM 464 OHM 1% 1/8W	
A1R56	0698-3449	RIFXD MET FLM 28.7K OHM 1% 1/8W	
A1R57	0698-3582	RIFXD MET FLM 41.2K OHM 1% 1/8W	
A1T1	9120-0066	TRANSFORMER:AUDIO	
A1T2	9120-0066	TRANSFORMER:AUDIO	
A1T3	9120-0065	TRANSFORMER:AUDIO	
A1T4	9120-0065	TRANSFORMER:AUDIO	
A1T5	9100-1677	TRANSFORMER:INPUT	
A2	00431-6019	BOARD ASSY:POWER SUPPLY	
A2C1	0180-0138	CIFXD ELECT 100UF -10+100% 40VDCW	
A2C2	0180-0049	CIFXD AL ELECT 20UF 50VDCW	
A2C3	0150-0093	CIFXD CER 0.01UF +80-20% 100VDCW	
A2C4	0150-0012	CIFXD CER 0.01 UF 20% 100VDCW	
A2C5	0160-0174	CIFXD CER 0.47UF +80-20% 25VDCW	
A2C6	0180-0059	CIFXD ELECT 10UF -10%+100% 25VDCW	
A2C7	0180-0105	CIFXD ELECT SEMI-POLARIZED 50UF 25VDCW	
A2C8	0150-0096	CIFXD CER 0.05UF 100VDCW	
A2C9	0180-0060	CIFXD ELECT 200UF -10%+100% 3VDCW	
A2CR1	1901-0025	DIODE:JUNCTION:15MA AT 1V 100 PIV	
A2CR2	1901-0025	DIODE:JUNCTION:15MA AT 1V 100 PIV	
A2CR3	1901-0025	DIODE:JUNCTION:15MA AT 1V 100 PIV	
A2CR4	1901-0025	DIODE:JUNCTION:15MA AT 1V 100 PIV	
A2CR5	1910-0016	DIODE:GERMANIUM 100MA AT 0.85V 60PIV	
A2CR6	1901-0026	DIODE:SILICON 200 PIV 0.5 AMP	
A2CR7	1901-0026	DIODE:SILICON 200 PIV 0.5 AMP	
A2Q1	1853-0020	TRANSISTOR:SILICON PNP	
A2Q2	1850-0064	TRANSISTOR:GERMANIUM PNP 2N1183	
A2Q3	1853-0020	TRANSISTOR:SILICON PNP	
A2Q4	1854-0071	TRANSISTOR:SILICON NPN 2N3391	
A2Q5	1854-0071	TRANSISTOR:SILICON NPN 2N3391	
A2Q6	1854-0071	TRANSISTOR:SILICON NPN 2N3391	
A2Q7	1854-0071	TRANSISTOR:SILICON NPN 2N3391	
A2Q8	1853-0020	TRANSISTOR:SILICON PNP	
A2R1	2100-1774	RIVAR COMP 2K OHM 10% LIN 1/2W	
A2R2	2100-1773	RIVAR WW 1K OHM 10% LIN 1/2W	

* See list of abbreviations in introduction to this section

Table 6-1. Reference Designation Index (Cont'd)

Reference Designation	Stock No.	Description #	Note
A2R3	2100-1772	RIVAR WW 500 OHM 10% LIN 1/2W	
A2R4	2100-1772	RIVAR WW 500 OHM 10% LIN 1/2W	
A2R5	2100-1771	RIVAR WW 200 OHM 10% LIN 1/2W	
A2R6	2100-1770	RIVAR COMP 100 OHM 10% LIN 1/2W	
A2R7	2100-1770	RIVAR COMP 100 OHM 10% LIN 1/2W	
A2R8	2100-1771	RIVAR WW 200 OHM 10% LIN 1/2W	
A2R9	2100-1772	RIVAR WW 500 OHM 10% LIN 1/2W	
A2R10	2100-1772	RIVAR WW 500 OHM 10% LIN 1/2W	
A2R11	2100-1774	RIVAR COMP 2K OHM 10% LIN 1/2W	
A2R12	2100-1774	RIVAR COMP 2K OHM 10% LIN 1/2W	
A2R13	2100-1774	RIVAR COMP 2K OHM 10% LIN 1/2W	
A2R14	2100-1774	RIVAR COMP 2K OHM 10% LIN 1/2W	
A2R15	0698-3337	RIFXD MET FLM 1.37K OHM 1% 1/2W	
A2R16	0757-0826	RIFXD MET FLM 2.43K OHM 1% 1/2W	
A2R17	0757-0436	RIFXD MET FLM 4.32K OHM 1% 1/8W	
A2R18	0757-0440	RIFXD MET FLM 7.50K OHM 1% 1/8W	
A2R19	0698-3581	RIFXD MET FLM 13.7K OHM 1% 1/8W	
A2R20	0757-0451	RIFXD MET FLM 24.3K OHM 1% 1/8W	
A2R21	0757-0456	RIFXD MET FLM 43.2K OHM 1% 1/8W	
A2R22	0757-0401	RIFXD MET FLM 100 OHM 1% 1/8W	
A2R23		NOT ASSIGNED	
A2R24	2100-1770	RIVAR COMP 100 OHM 10% LIN 1/2W	
A2R25	0757-0399	RIFXD MET FLM 82.5 OHM 1% 1/8W	
A2R26		NOT ASSIGNED	
A2R27	0699-0003	RIFXD COMP 8.2 OHM 10% 1/2W	
A2R28	0757-0279	RIFXD MET FLM 3.16K OHM 1% 1/8W	
A2R29	0698-3155	RIFXD MET FLM 4640 OHM 1% 1/8	
A2R30	0698-3132	RIFXD MET FLM 261 OHM 1% 1/8W	
A2R31	0757-0279	RIFXD MET FLM 3.16K OHM 1% 1/8W	
A2R32	0757-0274	RIFXD MET FLM 1.21K OHM 1% 1/8W	
A2R33	0757-0442	RIFXD MET FLM 10K OHM 1% 1/8W	
A2R34	0757-0439	RIFXD MET FLM 6.81K OHM 1% 1/8W	
A2R35	0757-0442	RIFXD MET FLM 10.0K OHM 1% 1/8W	
A2R36	2100-1774	RIVAR COMP 2K OHM 10% LIN 1/2W	
A2R37	0757-0442	RIFXD MET FLM 10K OHM 1% 1/8W	
A2R38	0698-3491	RIFXD MET FLM 1K OHM 0.1% 1/8W	
A2R39	0757-0290	RIFXD MET FLM 6.19K OHM 1% 1/8W	
A2R40	0757-0463	RIFXD MET FLM 82.5K 1% 1/8W	
A2R41	0757-0441	RIFXD MET FLM 8.25K OHM 1% 1/8W	
A2R42	0757-0180	RIFXD MET FLM 31.6 OHM 1% 1/8W	
A2R43	0757-0460	RIFXD MET FLM 61.9K OHM 1% 1/8W	
A2R44	0757-0123	RIFXD MET FLM 34.8K OHM 1% 1/8W	
A2R45	0757-0448	RIFXD MET FLM 18.2K OHM 1% 1/8W	
A2R46	0757-0442	RIFXD MET FLM 10K OHM 1% 1/8W	
A2R47	0757-0290	RIFXD MET FLM 6.19K OHM 1% 1/8W	
A2R48	0698-3411	RIFXD MET FLM 3.48K OHM 1% 1/8W	
A2R49	0698-3407	RIFXD MET FLM 1.96K OHM 1% 1/2W	
A2RT1	0439-0011	THERMISTOR 100 OHM 10%	
A2VR1	1902-0017	DIODE-BREAKDOWN 6.81V 10% 400 MW	

* See list of abbreviations in introduction to this section

Section VI
Table 6-1

Table 6-1. Reference Designation Index (Cont'd)

Reference Designation	Stock No.	Description #	Note
A2VR2	1902-0017	DIODE: BREAKDOWN: 6.81V 10% 400 MW	
A2VR3	1902-0596	DIODE: SILICON 9.0V	
A2Z1	431A-60A	COIL ASSEMBLY	
BT1	1420-0009	BATTERY: RECHARGEABLE 24V 1.25AH	
C1	0121-0035	CIVAR AIR 7.2-143.7PF	
C2	0150-0119	CIFXD CER 2 X 0.01 UF 20% 250VACW	
DS1	1450-0046	LAMP: NEON	
F1	2110-0004	FUSE: 1250V .25A	
F1	1400-0084	HOLDER: FUSE POST TYPE 3AG	
J1	1251-1280	CONNECTOR: 6 FEMALE CONTACTS THERMISTOR MOUNT	
J1	1251-1281	NUT: KNURLED	
J2	1250-0083	CONNECTOR: BNC RECORDER LEVELER	
J3	1251-0148	CONNECTOR: POWER 3 PIN MALE	
J4	1250-0083	CONNECTOR: BNC DVM	
J5	1251-1280	CONNECTOR: 6 FEMALE CONTACTS THERMISTOR MOUNT OPT 2	
J5	1251-1281	NUT: KNURLED	
J6	1510-0006	CONNECTOR: DC CALIBRATION INCL:	
J6	1510-0007	BINDING POST ASSEMBLY: BLACK	
J6	0340-0086	BINDING POST ASSEMBLY: RED	
J6	0340-0090	INSULATOR: BINDING POST	
J6	0340-0090	INSULATOR: BINDING-POST DOUBLE	
M1	1120-1101	METER	
R1		NOT ASSIGNED	
R2	2100-2631	RIVAR WW 10K 10% 800 OHM 10% LIN 2W	
R3		NOT ASSIGNED	
R4	0698-3151	RIFXD MET FLM 2.87K OHM 1% 1/8W	
R5	0757-0421	RIFXD MET FLM 825 OHM 1% 1/8W	
R6	0698-3444	RIFXD MET FLM 316 OHM 1% 1/8W-FACTORY SELECTED PART.	
R7	0698-3158	RIFXD MET FLM 23.7K OHM 1% 1/8W	
R8	0757-0280	RIFXD MET FLM 1.00K OHM 1% 1/8W	
R9	0698-3441	RIFXD MET FLM 215 OHM 1% 1/8W	
R10	0757-0398	RIFXD MET FLM 75 OHM 1% 1/8W	
R11	0757-0180	RIFXD MET FLM 31.6 OHM 1% 1/8W	
R12	0757-0277	RIFXD MET FLM 49.9 OHM 1% 1/8W	
R13	0757-0277	RIFXD MET FLM 49.9 OHM 1% 1/8W	
R14	0757-0277	RIFXD MET FLM 49.9 OHM 1% 1/8W	
R15	0698-3566	RIFXD MET FLM 53.0 OHM 1% 1/8W	
R16	0698-3566	RIFXD MET FLM 53.0 OHM 1% 1/8W	
R17	0698-3566	RIFXD MET FLM 53.0 OHM 1% 1/8W	
R18	0757-0395	RIFXD MET FLM 56.2 OHM 1% 1/8W	
R19	0757-0395	RIFXD MET FLM 56.2 OHM 1% 1/8W	
R20	0757-0395	RIFXD MET FLM 56.2 OHM 1% 1/8W	
R21	0757-1104	RIFXD MET FLM 60.0 OHM 1% 1/8W	

* See list of abbreviations in introduction to this section.

Table 6-1. Reference Designation Index (Cont'd)

Reference Designation	Stock No.	Description #	Note
R22	0757-1104	RIFXD MET FLM 60.0 OHM 1/8W	
R23	0757-1104	RIFXD MET FLM 60.0 OHM 1/8W	
R24	0698-3449	RIFXD MET FLM 28.7K OHM 1/8W	
R25	0698-4722	RESISTOR, FIXED 17.8K OHM(FACTORY SELECTED PART)	
R26	0757-0198	RIFXD MET FLM 100 OHM 1/2W	
R27	0757-0198	RIFXD MET FLM 100 OHM 1/2W	
R28	0698-3160	RIFXD MET FLM 31.6K 1/8W	
R29	0698-3404	RIFXD MET FLM 383 Ω 1/2W	
R30	0757-0821	RIFXD MET FLM 1.21K OHM 1/2W	
R31	THRU		
R32		NOT ASSIGNED	
R33	0698-0063	RIFXD MET FLM 5.23K OHM 1/8W	
S1	00431-6025	SWITCH ASSY:MOUNT RES	
S2	00431-6002	SWITCH ASSY:RANGE INCL:R4-R11	
S2	3100-1817	SWITCH:ROTARY	
S3	00431-6004	SWITCH ASSY:POWER INCL:R24,R26-R30	
S3	3100-1820	SWITCH:ROTARY	
S4	00431-6024	SWITCH ASSY:CAL INCL:R12-R23,R33	
S4	3100-1818	SWITCH:ROTARY	
T1	9100-0400	TRANSFORMER:POWER	
W1	8120-1082	CABLE ASSY:THERMISTOR MOUNT 5'	
W2	8120-0078	CABLE:POWER 7.5FT.	
XA1	1251-2239	CONNECTOR:PC 44 CONTACTS	
XA2	1251-2239	CONNECTOR:PC 44 CONTACTS	
		MISCELLANEOUS	
	0370-0064	KNOB VERNIER	
	0370-0067	KNOB:BLK CONCENTRIC 1 IN. OD 17/64IN. HOLE ZERO	
	0370-0112	KNOB:BLK BAR W/ARROW 3/4 IN. OD 1/4 SHAFT POWER CALIB FACTOR RANGE TRIMMETER	
	5020-0705	EXTENDER:METER CASE	
	5040-0701		
	00431-0004	BRACKET: PANEL	
	00431-6021	JUMPER: TEST POINT(A,B,C)	
		OPTION 01	
	00431-0005	DECK:MAIN(OPT 01)	
	00415-606	BATTERY INSTALLATION KIT, INCLUDES:	
	00415-006	COVER:BATTERY	
	2420-0001	NUT:HEX ST N° 6-32 X 5/16 W/LOCKWASHER	

* See list of abbreviations in Introduction to this section

Table 6-1. Reference Designation Index (Cont'd)

Reference Designation	Stock No.	Description #	Note
	00431-6102	OPT 02:CONVERSION KIT	
	00431-6109	OPT 09:CONVERSION KIT 10' CABLE	
	00431-6110	OPT 10:CONVERSION KIT 20' CABLE	
	00431-6111	OPT 11:CONVERSION KIT 50' CABLE	
	00431-6112	OPT 12:CONVERSION KIT 100' CABLE	
	00431-6113	OPT 13:CONVERSION KIT 200' CABLE	
	00431-6121	OPT 21:CONVERSION KIT 50' CABLE	
	00431-6122	OPT 22:CONVERSION KIT 100' CABLE	
	00431-6123	OPT 23:CONVERSION KIT 200' CABLE	
	00431-6124	OPT 24:CONVERSION KIT 200' CABLE	

* See list of abbreviations in Introduction to this section

Table 6-1. Reference Designation Index (Cont'd)

Reference Designation	Stock No.	Description #	Note
CABINET PARTS			
1	5060-0703	FRAME ASSEMBLY	
2	1490-0032	STAND TILT HALF-MODULE	
3	5040-0700	HINGE	
4	5060-0728	FOOT ASSY HALF-MODULE	
5	5020-0701	CABINET SPACER	
5	2370-0015	SCREW SST FH SLOT DR 6-32 X 3/8	
6	5000-0703	COVER SIDE	
6	2370-0020	SCREW SST FH PHIL DR 6-32 X 3/16	
7	5060-0720	COVER TOP	
7	2370-0016	SCREW SST FH PHIL DR 6-32 X 5/16	
8	5000-0717	COVER BOTTOM	
8	2370-0016	SCREW SST FH PHIL DR 6-32 X 5/16	
9	00431-0003	PANEL REAR	
9	2370-0015	SCREW SST FH 6-32 X 3/8 W/LOCKWASHER	
10	00431-0002	PANEL FRONT	
10	2370-0002	SCREW SST FH SLOT DR 6-32 X 3/8	

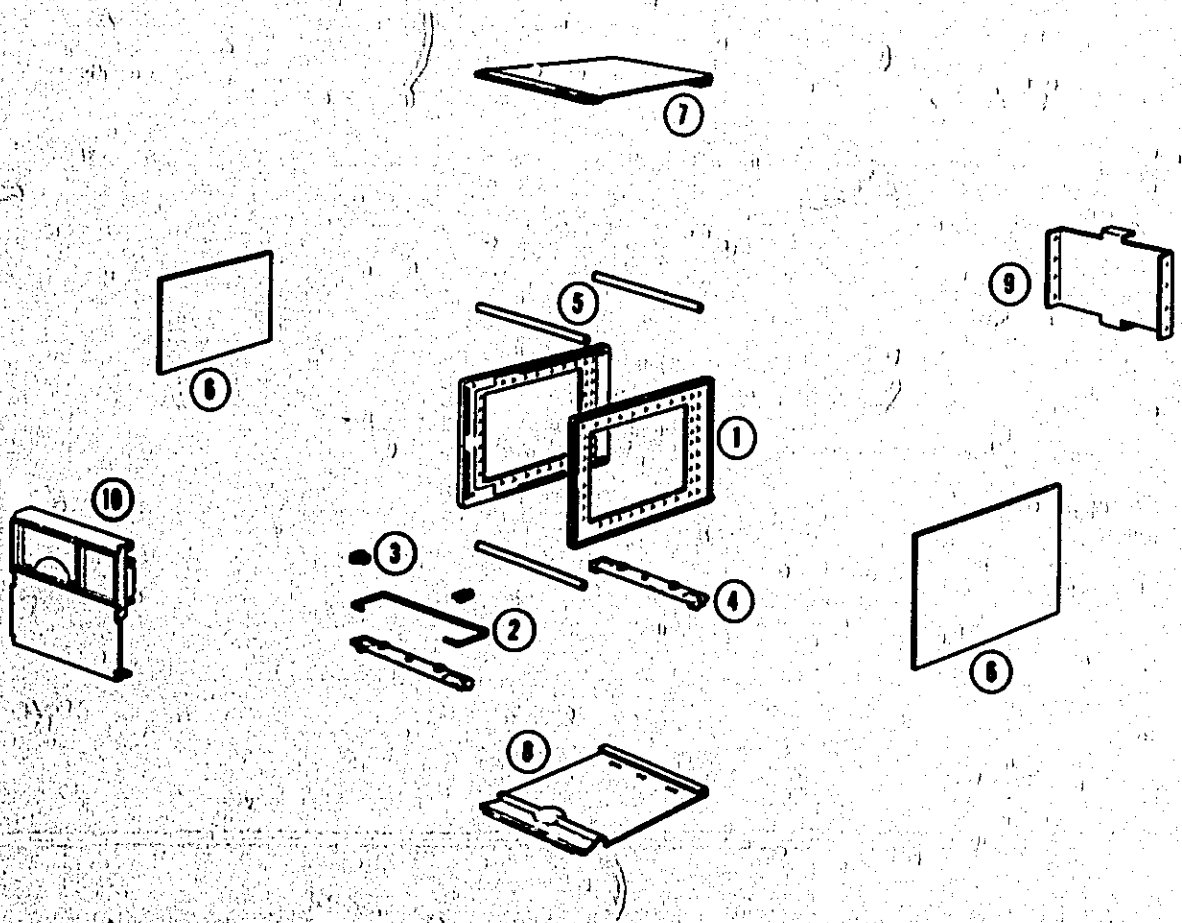

* See list of abbreviations in introduction to this section

Section VI
Table 6-2

Table 6-2. Replaceable Parts

Stock No.	Description #	Mfr.	Mfr. Part No.	TQ	RS
0121-0035	CIVAR AIR 7.2-143.7PF	28480	0121-0035	1	1
0140-0159	CIFXD MICA 300PF 300VDCW	72136	MDM19F302G35	1	1
0140-0198	CIFXD MICA 200PF 5% 300VDCW	72136	MDM15F201J3C	2	1
0150-0012	CIFXD CER 0.01 UF 20% 1000VDCW	56289	29C214A3-H-1038	1	1
0150-0093	CIFXD CER 0.01UF +80-20% 100VDCW	91418	TA	1	1
0150-0096	CIFXD CER 0.05UF 100VDCW	91418	-TA	1	1
0150-0119	CIFXD CER 2 X 0.01 UF 20% 250VACW	56289	36C219A	1	1
0160-0136	CIFXD MICA 2500 PF 1% 300VDCW	04062	RDM20F252F3C	2	1
0160-0174	CIFXD CER 0.47 UF +80-20% 25VDCW	56289	5C11A	4	1
0160-2201	CIFXD MICA 51 PF 5%	28480	0160-2201	1	1
0170-0069	CIFXD POLY 0.1UF 2% 50VDCW	56289	114P1042R553	3	1
0180-0045	CIFXD ELECT 20UF 25VDCW	56289	30D206-60-250B-6M1	2	1
0180-0049	CIFXD AL ELECT 20UF 50VDCW	56289	30D206G050DC6M1	2	1
0180-0059	CIFXD ELECT 10UF -10%+100% 25VDCW	56289	30D106G025BB4	1	1
0180-0060	CIFXD ELECT 200UF -10%+100% 3VDCW	56289	30D207G003DC4	1	1
0180-0105	CIFXD ELECT SEMI-POLARIZED 50UF 25VDCW	56289	034114	1	1
0180-0106	CIFXD ELECT TA 60UF 20% 6VDCW	56289	150D606X000682	1	1
0180-0116	CIFXD ELECT TA 6.8 UF 10% 35VDCW	56289	150D685X9035B2	6	2
0180-0138	CIFXD ELECT 100UF -10+100% 40VDCW	56289	036254	1	1
0340-0086	INSULATOR BINDING POST	28480	0340-0086	1	1
0340-0090	INSULATOR BINDING-POST DOUBLE	28480	0340-0090	1	1
0370-0064	KNOB	28480	0370-0064	1	1
0370-0067	KNOB BLK CONCENTRIC 1 IN. OD 17/64 IN. HOLE	28480	0370-0067	1	1
0370-0112	KNOB BLK BAR W/ARROW 3/4 IN. OD 1/4 SHAFT	28480	0370-0112	1	1
0698-0063	RIFXD MET FLM 5.23K OHM 1% 1/8W	28480	0698-0063	1	1
0698-0082	RIFXD MET FLM 464 OHM 1% 1/8W	28480	0698-0082	1	1
0698-0084	RIFXD MET FLM 2150 OHM 1% 1/8W	28480	0698-0084	1	1
0698-0085	RIFXD MET FLM 2.61K OHM 1% 1/8W	28480	0698-0085	1	1
0698-3132	RIFXD MET FLM 261 OHM 1% 1/8W	28480	0698-3132	1	1
0698-3151	RIFXD MET FLM 2.87K OHM 1% 1/8W	28480	0698-3151	1	1
0698-3155	RIFXD MET FLM 4640 OHM 1% 1/8W	28480	0698-3155	1	1
0698-3156	RIFXD MET FLM 14.7K OHM 1% 1/8W	28480	0698-3156	1	1
0698-3157	RIFXD MET FLM 19.6K OHM 1% 1/8W	28480	0698-3157	2	1
0698-3158	RIFXD MET FLM 23.7K OHM 1% 1/8W	19701	MF5C T-0	1	1
0698-3160	RIFXD MET FLM 31.6K 1% 1/8W	28480	0698-3160	2	1
0698-3337	RIFXD MET FLM 1.37K OHM 1% 1/8W	28480	0698-3337	1	1
0698-3404	RIFXD MET FLM 383 OHM 1% 1/8W	28480	0698-3404	1	1
0698-3407	RIFXD MET FLM 1.96K OHM 1% 1/8W	28480	0698-3407	1	1
0698-3411	RIFXD MET FLM 3.48K OHM 1% 1/8W	28480	0698-3411	1	1
0698-3438	RIFXD MET FLM 147 OHM 1% 1/8W	28480	0698-3438	1	1
0698-3440	RIFXD MET FLM 196 OHM 1% 1/8W	28480	0698-3440	1	1
0698-3441	RIFXD MET FLM 215 OHM 1% 1/8W	28480	0698-3441	1	1
0698-3444	RIFXD MET FLM 316 OHM 1% 1/8W	28480	0698-3444	1	1
0698-3447	RIFXD MET FLM 422 OHM 1% 1/8W	28480	0698-3447	1	1
0698-3449	RIFXD MET FLM 28.7K OHM 1% 1/8W	28480	0698-3449	3	1
0698-3450	RIFXD MET FLM 42.2K OHM 1% 1/8W	28480	0698-3450	1	1
0698-3452	RIFXD MET FLM 147K OHM 1% 1/8W	28480	0698-3452	1	1
0698-3491	RIFXD MET FLM 1K OHM 0.1% 1/8W	28480	0698-3491	1	1
0698-3546	RIFXD MET FLM 53.0 OHM 1% 1/8W	28480	0698-3546	3	1
0698-3581	RIFXD MET FLM 13.7K OHM 1% 1/8W	28480	0698-3581	1	1

* See list of abbreviations in introduction to this section

Table 6-2. Replaceable Parts (Cont'd)

Stock No.	Description #	Mfr.	Mfr. Part No.	TQ
0698-3582	RIFXD MET FLM 41.2K OHM 1% 1/8W	28480	0698-3582	1
0698-4023	RIFXD MET FLM 130.4K OHM 1/2% 1/8W	28480	0698-4023	1
0698-4024	RIFXD MET FLM 259.6K OHM 1/2% 1/8W	28480	0698-4024	1
0698-4025	RIFXD MET FLM 128.5K OHM 1/2% 1/8W	28480	0698-4025	1
0698-4026	RIFXD MET FLM 89.90K OHM 1/2% 1/8W	28480	0698-4026	1
0698-4027	RIFXD MET FLM 64.45K OHM 1/2% 1/8W	28480	0698-4027	1
0698-4028	RIFXD MET FLM 48.64K OHM 1/2% 1/8W	28480	0698-4028	2
0698-4029	RIFXD MET FLM 53.39K OHM 1/2% 1/8W	28480	0698-4029	1
0698-4030	RIFXD MET FLM 40.77K OHM 1/2% 1/8W	28480	0698-4030	1
0698-4031	RIFXD MET FLM 43.25K OHM 1/2% 1/8W	28480	0698-4031	1
0698-4032	RIFXD MET FLM 51.22K OHM 1/2% 1/8W	28480	0698-4032	1
0698-4033	RIFXD MET FLM 62.26K OHM 1/2% 1/8W	28480	0698-4033	1
0698-4034	RIFXD MET FLM 84.32K OHM 1/2% 1/8W	28480	0698-4034	1
0698-4722	RIFXD MET FLM 17.8K OHM 1/2% 1/8W	28480	0698-4722	1
0699-0003	RIFXD COMP B.2 OHM 10% 1/2W	28480	0699-0003	1
0757-0123	RIFXD MET FLM 34.8K OHM 1% 1/10W	28480	0757-0123	2
0757-0180	RIFXD MET FLM 31.6 OHM 1% 1/8W	28480	0757-0180	2
0757-0198	RIFXD MET FLM 100 OHM 1% 1/2W	28480	0757-0198	2
0757-0199	RIFXD MET FLM 21.5K OHM 1% 1/8W	28480	0757-0199	2
0757-0274	RIFXD MET FLM 1.21K OHM 1% 1/8W	28480	0757-0274	2
0757-0277	RIFXD MET FLM 49.9 OHM 1% 1/8W	28480	0757-0277	3
0757-0279	RIFXD MET FLM 3.16K OHM 1% 1/8W	28480	0757-0279	3
0757-0280	RIFXD MET FLM 1.00K OHM 1% 1/8W	28480	0757-0280	6
0757-0290	RIFXD MET FLM 6.19K OHM 1% 1/8W	28480	0757-0290	2
0757-0395	RIFXD MET FLM 56.2 OHM 1% 1/8W	28480	0757-0395	3
0757-0398	RIFXD MET FLM 75 OHM 1% 1/8W	28480	0757-0398	1
0757-0399	RIFXD MET FLM 82.5 OHM 1% 1/8W	28480	0757-0399	1
0757-0401	RIFXD MET FLM 100 OHM 1% 1/8W	28480	0757-0401	1
0757-0417	RIFXD MET FLM 562 OHM 1% 1/8W	28480	0757-0417	2
0757-0421	RIFXD MET FLM 825 OHM 1% 1/8W	28480	0757-0421	1
0757-0436	RIFXD MET FLM 4.32K OHM 1% 1/8W	28480	0757-0436	1
0757-0439	RIFXD MET FLM 6.81K OHM 1% 1/8W	28480	0757-0439	1
0757-0440	RIFXD MET FLM 7.50K OHM 1% 1/8W	28480	0757-0440	3
0757-0441	RIFXD MET FLM 8.25K OHM 1% 1/8W	28480	0757-0441	1
0757-0442	RIFXD MET FLM 10.0K OHM 1% 1/8W	28480	0757-0442	6
0757-0448	RIFXD MET FLM 18.2K OHM 1% 1/8W	28480	0757-0448	1
0757-0451	RIFXD MET FLM 24.3K OHM 1% 1/8W	28480	0757-0451	1
0757-0456	RIFXD MET FLM 43.2K OHM 1% 1/8W	28480	0757-0456	1
0757-0460	RIFXD MET FLM 61.9K OHM 1% 1/8W	28480	0757-0460	2
0757-0463	RIFXD MET FLM 82.5K 1% 1/8W	28480	0757-0463	1
0757-0465	RIFXD MET FLM 100K OHM 1% 1/8W	28480	0757-0465	1
0757-0821	RIFXD MET FLM 1.21K OHM 1% 1/2W	28480	0757-0821	1
0757-0826	RIFXD MET FLM 2.43K OHM 1% 1/2W	28480	0757-0826	1
0757-1094	RIFXD MET FLM 1.47K OHM 1% 1/8W	28480	0757-1094	1
0757-1104	RIFXD MET FLM 60.0 OHM 1% 1/8W	28480	0757-1104	3
0811-0065	RIFXD WW 511 OHM 1.0% 1/20W	28480	0811-0065	2
0811-0066	RIFXD WW 887 OHM 1% 8/100W	99957	M3A/887-1% 8/100W	1
0811-1566	RIFXD WW 200 OHM 0.1% 1/8W	28480	0811-1566	1
0811-1571	RIFXD WW 189 OHM 0.1% 1/8W	28480	0811-1571	1
0811-1572	RIFXD WW 255 OHM 0.1% 1/8W	28480	0811-1572	1
0811-1645	RIFXD WW 202.1 OHM 0.1% 1/8W	28480	0811-1645	1

* See list of abbreviations in introduction to this section

Table 6-2. Replaceable Parts (Cont'd)

Stock No.	Description #	Mfr.	Mfr. Part No.	TQ	RS
0839-0011	THERMISTOR:100 OHM 10%	33173	20-204	1	1
1120-1101	METER	28480	1120-1101	1	1
1250-0083	CONNECTOR:8NC	28480	1250-0083	2	1
1251-0148	CONNECTOR:POWER 3 PIN MALE	60427	H-1061-2	1	1
1251-1280	CONNECTOR:PC 6 FEMALE CONTACTS	28480	1251-1280	2	1
1251-1281	NUT:KNURLED				
1251-2239	CONNECTOR:PC 44 CONTACTS	28480	1251-1281	2	1
1400-0084	HOLDER:FUSE POST TYPE 3AG	28480	1251-2239	2	1
1420-0009	BATTERY:RECHARGEABLE 24V 1.25AH	75915	342014	1	10
1450-0048	LAMP:NEON	28480	1420-0009	1	1
		28480	1350-0048	1	1
1490-0032	STAND:TILT:HALF-MODULE				
1510-0006	BINDING POST ASSEMBLY:BLACK	28480	1490-0032	1	
1510-0007	BINDING POST ASSEMBLY:RED	28480	1510-0006	1	1
1850-0064	TRANSISTOR:GERMANIUM PNP 2N1183	28480	1510-0007	1	1
1853-0020	TRANSISTOR:SILICON PNP	02735	2N1183	1	1
		28480	1853-0020	5	9
1854-0071	TRANSISTOR:SILICON NPN 2N3391	89473	16A792		
1901-0025	DIODE:JUNCTION:15MA AT 1V 100 PIV	28480	1901-0025	9	9
1901-0026	DIODE:SILICON 200 PIV 0.5 AMP	28480	1901-0026	7	7
1901-0450	DIODE:SILICON	28480	1901-0450	2	2
1902-0017	DIODE:BREAKDOWN:6.81V 10% 400 MB	28480	1901-0450	8	8
		28480	1902-0017	2	1
1902-0596	DIODE:SILICON 9.0V				
1910-0016	DIODE:GERMANIUM 100MA AT 0.85V 60PIV	28480	1902-0596	1	1
2100-0144	R:VAR COMP 250K OHM 30% LIN 1/2W	28480	1910-0016	5	5
		28480	2100-0144	1	1
2100-1770	R:VAR COMP 100 OHM 10% LIN 1/2W				
		28480	2100-1770	3	1
2100-1771	R:VAR WW 200 OHM 10% LIN 1/2W				
2100-1772	R:VAR WW 500 OHM 10% LIN 1/2W	28480	2100-1771	2	1
2100-1773	R:VAR WW 1K OHM 10% LIN 1/2W	28480	2100-1772	4	1
2100-1774	R:VAR COMP 2K OHM 10% LIN 1/2W	28480	2100-1773	1	1
2100-2631	R:VAR WW 10K 10% 800 OHM 10% LIN	28480	2100-1774	6	2
2110-0004	FUSE:250V .25A	28480	2100-2631	1	1
2370-0002	SCREW:ST FH SLOT DR 6-32 X 3/8	28480	2110-0004	1	10
2370-0015	SCREW:ST FH SLOT DR 6-32 X 3/8	00000	08D	1	
2370-0016	SCREW:ST FH PHIL DR 6-32 X 5/16	00000	08D	2	
2370-0020	SCREW:ST FH PHIL DR 6-32 X 3/16	00000	08D	2	
2420-0001	NUT:HEX ST NP 6-32 X 5/16 W/LOCKWASHER	00000	08D	1	
		78189	08D	4	
3100-1817	SWITCH:ROTARY				
3100-1818	SWITCH:ROTARY	28480	3100-1817	1	1
3100-1820	SWITCH:ROTARY	28480	3100-1818	1	1
5000-0703	COVER:SIDE	28480	3100-1820	1	1
5000-0717	COVER:BOTTOM	28480	5000-0703	1	
		28480	5000-0717	1	
5020-0701	CABINET SPACER				
5020-0705	TRIM:METER	28480	5020-0701	1	
5040-0700	HINGE	28480	5020-0705	1	
5040-0701	EXTENDER:METER CASE	28480	5040-0700	1	
5060-0703	FRAME, ASSEMBLY	28480	5040-0701	1	
		28480	5060-0703	1	
5060-0720	COVER:TOP				
5060-0728	FOOT ASSY:HALF-MODULE	28480	5060-0720	1	
8120-0078	CABLE:POWER 7.5FT.	28480	5060-0728	1	
8120-1082	CABLE ASSY:15 FT.	70903	KH4147	1	1
9100-0400	TRANSFORMER:POWER	28480	8120-1082	1	1
9100-1677	TRANSFORMER:INPUT	28480	9100-0400	1	1
		28480	9100-1677	1	1

* See list of abbreviations in introduction to this section

Table 6-2. Replacesble Parts (Cont'd)

Stock No.	Description #	Mfr.	Mfr. Part No.	TQ
9110-0040	INDUCTOR: AUDIO	98734	9110-0040	2
9120-0065	TRANSFORMER: AUDIO	28480	9120-0065	2
9120-0066	TRANSFORMER: AUDIO	28480	9120-0066	2
9140-0122	COIL: VAR 2X 9-20 UHY EACH	28480	9140-0122	2
00415-006	COVER: BATTERY	28480	00415-006	1
00415-606	BATTERY INSTALLATION KIT	28480	00415-606	1
00431-0002	PANEL: FRONT	28480	00431-0002	1
00431-0003	PANEL: REAR	28480	00431-0003	1
00431-0004	BRACKET: PANEL	28480	00431-0004	1
00431-0005	DECK: HAIR (OPT 01)	28480	00431-0005	1
00431-6002	SWITCH ASSY: RANGE INCL: R4-R11	28480	00431-6002	1
00431-6004	SWITCH ASSY: POWER INCL: R24-R28-R30	28480	00431-6004	1
00431-6018	BOARD ASSY: AMPLIFIER	28480	00431-6018	1
00431-6019	BOARD ASSY: POWER SUPPLY	28480	00431-6019	1
00431-6021	JUMPER: TEST POINT (A, B, C)	28480	00431-6021	1
00431-6024	SWITCH ASSY: CAL INCL: R12-R23, R33	28480	00431-6024	1
00431-6025	SWITCH ASSY: MOUNT RES	28480	00431-6025	1
00431-6102	OPT 02: CONVERSION KIT	28480	00431-6102	1
00431-6109	OPT 09: CONVERSION KIT 10' CABLE	28480	00431-6109	1
00431-6110	OPT 10: CONVERSION KIT 20' CABLE	28480	00431-6110	1
00431-6111	OPT 11: CONVERSION KIT 30' CABLE	28480	00431-6111	1
00431-6112	OPT 12: CONVERSION KIT 100' CABLE	28480	00431-6112	1
00431-6113	OPT 13: CONVERSION KIT 200' CABLE	28480	00431-6113	1
00431-6121	OPT 21: CONVERSION KIT 50' CABLE	28480	00431-6121	1
00431-6122	OPT 22: CONVERSION KIT 100' CABLE	28480	00431-6122	1
00431-6123	OPT 23: CONVERSION KIT 200' CABLE	28480	00431-6123	1
00431-6124	OPT 24: CONVERSION KIT 200' CABLE	28480	00431-6124	1
431A-60A	COIL ASSEMBLY	28480	431A-60A	1

* See list of abbreviations in introduction to this section

TABLE 6-3.
CODE LIST OF MANUFACTURERS

The following code numbers are from the Federal Supply Code for Manufacturers Cataloging Handbooks H4-1 (Name to Code) and H4-2 (Code to Name) and their latest supplements. The date of revision and the date of the supplements used appear at the bottom of each page. Alphabetical codes have been arbitrarily assigned to suppliers not appearing in the H4 Handbooks.

Code No.	Manufacturer	Address	Code No.	Manufacturer	Address	Code No.	Manufacturer	Address
00000	U. S. A. Common	Any supplier of U. S.	05245	Components Corp.	Chicago, Ill.	09145	Tech. Ind. Inc. Altkm Elect.	Burbank, Calif.
00136	McCoy Electronics	Mount Holly Springs, Pa.	05277	Westinghouse Electric Corp.		09250	Electro Assemblies, Inc.	Chicago, Ill.
00213	Sage Electronics Corp.	Rochester, N. Y.		Semi-Conductor Dept.	Youngwood, Pa.	09353	C & K Components Inc.	Newton, Mass.
00287	Comco Inc.	Danielson, Conn.	05347	Ultronix, Inc.	San Mateo, Calif.	09569	Battery Battery Co. of	Canada, Ltd.
00334	Humidist	Colton, Calif.	05397	Union Carbide Corp., Elect. Div.				Toronto, Ontario, Canada
00346	Microtron Co., Inc.	Valley Stream, N. Y.			New York, N. Y.	09922	Bundy Corp.	Norwalk, Conn.
00373	Gortack Inc.	Cherry Hill, N. J.	05574	Viking Ind. Inc.	Conoga Park, Calif.	10216	General Transistor Western Corp.	Los Angeles, Calif.
00656	Aerovox Corp.	New Bedford, Mass.	05593	Icore Electro-Plastics Inc.	Sunnyvale, Calif.			Berkeley, Calif.
00779	Amp. Inc.	Harrisburg, Pa.	05616	Cosmo Plastic		10411	Ti-Tel, Inc.	Niagara Falls, N. Y.
00781	Aircraft Radio Corp.	Boston, N. J.		(c/o Electrical Spec. Co.)	Cleveland, Ohio	11216	CTS of Berns, Inc.	Berne, Ind.
00816	Northern Engineering Laboratories, Inc.	Berlington, Wis.	05624	Barber Colman Co.	Rockford, Ill.	11237	Chicago Telephone of California, Inc.	
			05728	Tiffen Optical Co.				So. Pasadena, Calif.
00853	Sangamo Electric Co., Picheas Div.	Picheas, S. C.	05729	Metro-Tel Corp.	Restyn Heights, Long Island, N. Y.	11242	Bay State Electronics Corp.	Waltham, Mass.
00866	Gee Engineering Co.	City of Industry, Cal.	05783	Stewart Engineering Co.	San Jose, Calif.	11312	Teledyne Inc., Microwave Div.	Palo Alto, Calif.
00891	Carl E. Holmes Corp.	Los Angeles, Calif.	05820	Wahfield Engineering Inc.	Wahfield, Mass.	11314	National Seal	Dunaway, Calif.
00929	Nicrofab Inc.	Livingston, N. J.	06004	Bausch Co., Div. of Stewart Warner Corp.		11453	Precision Connector Corp.	Jamaica, N. Y.
01002	General Electric Co., Capacitor Dept.	Madison Falls, N. Y.			Bridgeport, Conn.	11574	Duncan Electronics Inc.	Costa Mesa, Calif.
			06030	Raychem Corp.	Redwood City, Calif.	11711	General Instrument Corp., Semiconductor	
01009	Alden Products Co.	Brockton, Mass.	06135	Bausch and Lomb Optical Co.	Rochester, N. Y.		Div., Products Group	Newark, N. J.
01121	Allen Bradley Co.	Milwaukee, Wis.	06402	E. T. A. Products Co. of America	Chicago, Ill.	11717	Imperial Electronic, Inc.	Queens Park, Calif.
01295	Litton Industries, Inc.	Beverly Hills, Calif.	06590	Amalek Electronic Hardware Co., Inc.		11870	Meluba, Inc.	Palo Alto, Calif.
01281	TRW Semiconductors, Inc.	Lawndale, Calif.			New Rochelle, N. Y.	12040	National Semiconductor	Danbury, Conn.
01295	Texas Instruments, Inc.		06555	Beede Electrical Instrument Co., Inc.		12126	Philadelphia Handle Co.	Camden, N. J.
	Transistor Products Div.	Dallas, Texas			Ponacook, N. H.	12361	Grove Mfg. Co., Inc.	Shady Grove, Pa.
01349	The Alliance Mfg. Co.	Alliance, Ohio	06666	General Devices Co., Inc.	Indianapolis, Ind.	12574	Gulton Ind. Inc. Data System Div.	Albuquerque, N. M.
01589	Pacific Relays, Inc.	Van Nuys, Calif.	06751	Components Inc., Ariz. Div.	Phoenix, Ariz.			Dever, N. H.
01670	Gudebrod Bros. Silk Co.	New York, N. Y.	06812	Torrington Mfg. Co., West Div.		12697	Clorostat Mfg. Co.	W. Haven, Conn.
01930	Amerock Corp.	Rockford, Ill.			Van Nuys, Calif.	12728	Elmar Filter Corp.	Tokyo, Japan
01961	Pulco Engineering Co.	Santa Clara, Calif.	06990	Varian Assoc. Elmac Div.	San Carlos, Calif.	12859	Nippon Electric Co., Ltd.	Clark, N. J.
02114	Fairbanks Corp. of America	Saugerties, N. Y.	07088	Kelvin Electric Co.	Van Nuys, Calif.	12881	Motex Electronics Corp.	Newport Beach, Calif.
02116	Whentech Signals, Inc.	Long Branch, N. J.	07126	Digitran Co.	Pasadena, Calif.	12930	Delta Semiconductor Inc.	Scottsdale, Arizona
02286	Cole Rubber and Plastics Inc.	Sunnyvale, Calif.	07137	Transistor Electronics Corp.	Minneapolis, Minn.	12954	Dickson Electronics Corp.	Dallas, Texas
02640	Amphenol-Borg Electronics Corp.	Broadview, Ill.	07138	Westinghouse Electric Corp.		13103	Thermolloy	Hanover, Germany
02735	Radio Corp. of America, Semiconductor and Materials Div.	Somerville, N. J.		Electronic Tube Div.	Elms, N. Y.	13356	Telefunken (GmbH)	Newbury Park, Calif.
			07149	Filmoban Corp.	New York, N. Y.	13935	Midland-Night Div. of Pacific Industries, Inc.	Kansas City, Kansas
02771	Vocaline Co. of America, Inc.	Old Saybrook, Conn.	07233	Cinch-Graphik Co.	City of Industry, Calif.			Newbury Park, Calif.
02777	Hopkins Engineering Co.	San Fernando, Calif.	07256	Silicon Transistor Corp.	Carle Plaza, N. Y.	14099	Sem-Tech	Santa Monica, Calif.
02815	Hudson Tool & Die Co.	Nowak, N. J.	07261	Avnet Corp.	Culver City, Calif.	14298	American Components, Inc.	Conshohocken, Pa.
03500	G. E. Semiconductor Prod. Dept.	Syracuse, N. Y.	07263	Fairchild Camera & Inst. Corp.		14433	ITT Semiconductor, A Div. of Int. Telephone & Telegraph Corp.	West Palm Beach, Fla.
03705	Ayco Machine & Tool Co.	Dayton, Ohio		Semiconductor Div.	Mountain View, Calif.	14493	Newlett Packard Company	Levelland, Colo.
03797	Eldemo Corp.	Compton, Calif.	07322	Minnesota Rubber Co.	Minneapolis, Minn.	14655	Corwell Dublier Electric Corp.	Newark, N. J.
03818	Parker Seal Co.	Los Angeles, Calif.	07387	Bircher Corp., The	Monterey Park, Calif.	14674	Corning Glass Works	Corning, N. Y.
03817	Transitron Electric Corp.	Wahfield, Mass.	07397	Sylvania Elect. Prod. Inc., MT. View Operations	Mountain View, Calif.	14752	Electro Cube Inc.	San Gabriel, Calif.
03888	Pyrofilm Resistor Co., Inc.	Cedar Knolls, N. J.			Cranford, N. J.	14960	Williams Mfg. Co.	San Jose, Calif.
03954	Singer Co., Djah Div.		07700	Technical Wire Products Inc.	Chicago, Ill.	15203	Webster Electronics Co.	New York, N. Y.
	Finderne Plant	Somerville, N. J.	07829	Bodine Elect. Co.	Hawthorne, Calif.	15287	Scionics Corp.	Northridge, Calif.
04009	Arrow, Hart & Hegeman Elect. Co.	Hartford, Conn.	07910	Continental Device Corp.		15291	Adjustable Bushing Co.	N. Hollywood, Calif.
			07933	Raytheon Mfg. Co.		15558	Micron Electronics	Garden City, Long Island, N. Y.
04013	Taurus Corp.	Lambertville, N. J.		Semiconductor Div.	Mountain View, Calif.			Lynbrook, N. Y.
04062	Aico Electronic Inc.	Great Neck, N. Y.	07949	Hewlett-Packard Co., Boolean Radio Div.	Rockaway, N. J.	15566	Amprobe Inst. Corp.	Costa Mesa, Calif.
04222	Hi-Q Division of Aerovox	Myrtle Beach, S. C.			Los Angeles, Calif.	15631	Cabletronics	Costa Mesa, Calif.
04354	Precision Paper Tube Co.	Wheeling, Ill.	08145	U.S. Engineering Co.	Los Angeles, Calif.	15772	Twentieth Century Call Spring Co.	Santa Clara, Calif.
04464	Dynac Division of Hewlett-Packard Co.	Palo Alto, Calif.	08289	Bilion, Delbert Co.	Pomona, Calif.			Framingham, Mass.
			08358	Burgess Battery Co.	Niagara Falls, Ontario, Canada	15818	Amelco Inc.	Mt. View, Calif.
04451	Sylvania Electric Products, Microwave Device Div.	Mountain View, Calif.			Los Angeles, Calif.	16037	Spruce Pine Mica Co.	Spruce Pine, N. C.
04673	Dakota Eng. Inc.	Culver City, Calif.	08664	Bristol Co., The	Watersbury, Conn.	16179	Omni-Spectra Inc.	Farmington, Mich.
04713	Melara, Inc., Semiconductor Prod. Div.	Phoenix, Arizona	08717	Sloan Company	San Valley, Calif.	16352	Computer Diode Corp.	Lodi, N. J.
			08727	ITT Compaq Electric Inc., Phoenix Div.	Phoenix, Arizona	16385	Booth Aircraft Met Corp.	Pasadena, Calif.
04732	Filltron Co., Inc. Western Div.	Culver City, Calif.	08727	National Radio Lab. Inc.	Paramus, N. J.	16688	Ideal Prec. Meter Co., Inc.	Brooklyn, N. Y.
							De Jur Meter Div.	Kahama, Ind.
04773	Automatic Electric Co.	Northlake, Ill.	08792	CBS Electronics Semiconductor Operations, Div. of C. B. S. Inc.		16750	Delco Radio Div. of G. M. Corp.	Conoga Park, Calif.
04796	Sequela Wire Co.	Redwood City, Calif.			Lowell, Mass.	17189	Thermonics Inc.	Mountain View, Calif.
04811	Precision Coil Spring Co.	El Monte, Calif.	08826	General Electric Co. Wialz. Lamp Dept.	Cleveland, Ohio	17374	Tronex Company	Bliddeford, Wa.
04870	P. M. Motor Company	Worcester, Ill.			Indianapolis, Ind.	17554	Components Inc.	Akron, Ohio
04919	Component Mfg. Service Co.	W. Bridgewater, Mass.	08884	Mel-Rain	Costa Mesa, Calif.	17675	Hemlin Metal Products Corp.	No. Hollywood, Calif.
05006	Twentieth Century Plastics, Inc.	Los Angeles, Calif.	09226	Babcock Relays Div.	Houston, Texas			
			09134	Texas Capacitor Co.				

TABLE 6-3.

CODE LIST OF MANUFACTURERS (Continued)

Code No.	Manufacturer	Address	Code No.	Manufacturer	Address	Code No.	Manufacturer	Address
17670	McGraw-Edison Co.	Manchester, N. H.	62119	Universal Electric Co.	Owosso, Mich.	73859	JFD Electronics Corp.	Brooklyn, N. Y.
18042	Power Design Pacific Inc.	Palo Alto, Calif.	63743	Ward-Leonard Electric Co.	Ni. Verona, N. Y.	73905	Jennings Radio Mfg. Corp.	San Jose, Calif.
18403	Clevite Corp., Semiconductor Div.	Palo Alto, Calif.	64959	Western Electric Co., Inc.	New York, N. Y.	73957	Gray-Pin Corp.	Ridgefield, N. J.
18324	Signetics Corp.	Sunnyvale, Calif.	65092	Western Inst. Inc. Weston-Newark	Newark, N. J.	74276	Signalite Inc.	Keplene, N. J.
18476	Ty-Car Mfg. Co., Inc.	Holliston, Mass.	66295	Willsh Mfg. Co.	Chicago, Ill.	74455	J. H. Wiann, and Sons	Worcester, Mass.
18484	TRW Elec. Comp. Div.	Des Plaines, Ill.	66346	Minnesota Wiring & Mfg. Co.	Revere Mincom Div. St. Paul, Minn.	74661	Industrial Condense; Corp.	Chicago, Ill.
18503	Curtis Instrument, Inc.	Mt. Kisco, N. Y.	70276	Allen Mfg. Co.	Hartford, Conn.	74860	R. F. Products Division of Amphenol-Borg Electronics Corp.	Danbury, Conn.
18512	Vishay Instruments Inc.	Malvern, Pa.	70309	Allied Control	New York, N. Y.	74970	E. F. Johnson Co.	Waukegan, Minn.
18673	E. I. DuPont and Co., Inc.	Wilmington, Del.	70318	Allmetal Screw Product Co., Inc.	Garden City, N. Y.	75042	International Resistance Co.	Philadelphia, Pa.
18911	Durast Mfg. Co.	Milwaukee, Wis.	70417	Ampl. Div. of Chrysler Corp.	Detroit, Mich.	75263	Keystone Carbon Co., Inc.	St. Marys, Pa.
19315	The Bendix Corp., Navigation & Control Div.	Teterboro, N. J.	70485	Alliant India Rubber Works, Inc.	Chicago, Ill.	75378	CTS Knights Inc.	Sandwich, Ill.
19500	Thomas A. Edison Industries, Div. of McGraw-Edison Co.	West Orange, N. J.	70563	Amperex Co., Inc.	Union City, N. J.	75382	Kulha Electric Corporation	Ni. Verona, N. Y.
19589	Concoa	Baldwin Park, Calif.	70674	ADC Products Inc.	Minneapolis, Minn.	75818	Loez Electric Mfg. Co.	Chicago, Ill.
19640	LRC Electronics	Northvale, N. Y.	70903	Bird Electronic Corp.	Chicago, Ill.	75915	Lillifense, Inc.	Des Plaines, Ill.
19701	Electra Mfg. Co.	Independence, Kansas	71002	Birabach Radio Co.	Cleveland, Ohio	76005	Lord Mfg. Co.	Erie, Pa.
20103	General Atomics Corp.	Philadelphia, Pa.	71034	Billroy Electric Co., Inc.	New York, N. Y.	76210	C. W. Hornadel	San Francisco, Calif.
21226	Esaculosa, Inc.	Long Island City, N. Y.	71041	Boston Gear Works Div. of Murray Co. of Texas	Quincy, Mass.	76433	General Instrument Corp., Nicomold Division	Newark, N. J.
21325	Falric Bearing Co., The	New Britain, Conn.	71218	Bud Radio, Inc.	Willoughby, Ohio	76487	James Milton Mfg. Co., Inc.	Malden, Mass.
21329	Fonsteel Metallurgical Corp.	N. Chicago, Ill.	71279	Cambridge Thermoionics Corp.	Cambridge, Mass.	76493	J. W. Miller Co.	Los Angeles, Calif.
23042	Toxscan Corp.	Indianapolis, Ind.	71286	Camloc Fastener Corp.	Paramus, N. J.	76530	Cinch-Monadnock, Div. of United Corr Fastener Corp.	San Leandro, Calif.
23283	British Radio Electronics Ltd.	Washington, D. C.	71313	Cardwell Condenser Corp.	Lindenhurst L. I., N. Y.	76545	Muller Electric Co.	Cleveland, Ohio
24455	G. E. Lamp Division	Nela Park, Cleveland, Ohio	71400	Bussmann Mfg. Div. of McGraw-Edison Co.	St. Louis, Mo.	76703	National Union	Newark, N. J.
24655	General Radio Co.	West Concord, Mass.	71436	Chicago Condenser Corp.	Chicago, Ill.	76858	Oak Manufacturing Co.	Crystal Lake, Ill.
24681	Honcor Inc., Comp. Div.	Wilmington, Ind.	71447	Calif. Spring Co., Inc.	Pico-Rivera, Calif.	77068	The Bendix Corp., Electrodynamics Div.	N. Hollywood, Calif.
24796	Paralco Inc.	San Jose Capistrano, Calif.	71450	CTS Corp.	Elkhart, Ind.	77075	Pacific Metals Co.	San Francisco, Calif.
25365	Gries Reproducer Corp.	New Rochelle, N. Y.	71460	ITT Cannon Electric Inc.	Los Angeles, Calif.	77221	Phonotron Instrument and Electronic Co.	South Pasadena, Calif.
26462	Grebel File Co. of America, Inc.	Carlstadt, N. J.	71471	Cinema, Div. Aerovox Corp.	Burbank, Calif.	77252	Philadelphia Steel and Wire Corp.	Philadelphia, Pa.
26851	Compact/Hillister Co.	Hollister, Calif.	71482	C. P. Clare & Co.	Chicago, Ill.	77342	American Machine & Foundry Co. Peltier & Brunfeld Div.	Prieston, Ind.
26932	Hamilton Watch Co.	Lowchester, Pa.	71590	Centralab Div. of Globe Union Inc.	Milwaukee, Wis.	77630	TRW Electronic Components Div.	Cumden, N. J.
27251	Specialties Mfg. Co., Inc.	Sturford, Conn.	71616	Commercial Plastics Co.	Chicago, Ill.	77638	General Instrument Corp., Rectifier Div.	Brooklyn, N. Y.
28400	Hewlett-Packard Co.	Palo Alto, Calif.	71700	Cornish Wire Co., The	New York, N. Y.	77764	Resistance Products Co.	Harrisburg, Pa.
28520	Heyman Mfg. Co.	Kenilworth, N. J.	71707	Cole Coil Co., Inc.	Providence, R. I.	77969	Rubbercraft Corp. of Calif.	Torrance, Calif.
30617	Instrument Specialties Co., Inc.	Little Falls, N. J.	71744	Chicago Miniature Lamp Works	Chicago, Ill.	78189	Shakeproof Division of Illinois Tool Works	Elgin, Ill.
33173	G. E. Receiving Tube Dept.	Oenoboro, Ky.	71785	Cinch Mfg. Co., Howard B. Jones Div.	Chicago, Ill.	78277	Sigma	So. Braintree, Mass.
35034	Lectrahm Inc.	Chicago, Ill.	71984	Dow Corning Corp.	Midland, Mich.	78283	Signal Indicator Corp.	New York, N. Y.
36186	Stawych Coil Products Ltd.	Hawkesbury, Ontario, Canada	72136	Electro Motive Mfg. Co., Inc.	Williamsville, Conn.	78290	Stulbers-Cann Inc.	Pilman, N. J.
36287	Cunningham, W. H. & Hill, Ltd.	Toronto Ontario, Canada	72619	Dialight Corp.	Brooklyn, N. Y.	78424	Speciality Leather Prod. Co.	Newark, N. J.
37942	P. R. Mallory & Co. Inc.	Indianapolis, Ind.	72656	Indiana General Corp., Electronics Div.	Keasby, N. J.	78452	Thompson-Bremer & Co.	Chicago, Ill.
39543	Mechanical Industries Prod. Co.	Akron, Ohio	72699	General Instrument Corp., Cop. Div. Newark, N. J.	Keasby, N. J.	78471	Tilley Mfg. Co.	San Francisco, Calif.
40920	Miniature Precision Bearings, Inc.	Keene, N. H.	72765	Naake Mfg. Co.	Narwood Heights, Ill.	78488	Stachpole Carbon Co.	St. Marys, Pa.
42130	Muter Co.	Chicago, Ill.	72825	Hugh H. Eby Inc.	Philadelphia, Pa.	78493	Standard Thomson Corp.	Waltham, Mass.
43930	C. A. Morgan Co.	Englewood, Colo.	72928	Gudeman Co.	Chicago, Ill.	78553	Tinnerman Products, Inc.	Cleveland, Ohio
44655	Omnite Mfg. Co.	Shakie, Ill.	72962	Elastic Stop Nut Corp.	Union, N. J.	78790	Transformer Engineers	San Gabriel, Calif.
46384	Penn Eng. & Mfg. Corp.	Dayton, Pa.	72964	Robert M. Hadley Co.	Los Angeles, Calif.	78947	Ucinite Co.	Newtownville, Mass.
47904	Polaroid Corp.	Cambridge, Mass.	72982	E. o Technological Products, Inc.	Erie, Pa.	79126	Walces Koblaser Inc.	Long Island City, N. Y.
48620	Precision Thermometer & Inst. Co.	Southampton, Pa.	73061	Hanson Mfg. Co., Inc.	Plympton, Ind.	79142	Veeder Root, Inc.	Hartford, Conn.
49956	Microwave & Power Tube Div.	Waltham, Mass.	73076	H. M. Harper Co.	Chicago, Ill.	79251	Weaco Mfg. Co.	Chicago, Ill.
52090	Roman Controller Co.	Westminster, Md.	73138	Helipot Div. of Beckman Inst., Inc.	Fallerton, Calif.	79727	Continental-Witt Electronics Corp.	Philadelphia, Pa.
52993	Sandern Company	Waltham, Mass.	73293	Hughes Products Division of Hughes Aircraft Co.	Newport Beach, Calif.	79963	Zierich Mfg. Corp.	New Rochelle, N. Y.
54294	Shallcross Mfg. Co.	Seima, N. C.	73445	Amperex Elect Co.	Nicholsville, L. I., N. Y.	80031	Nepco Division of Sessions Clock Co.	Morristown, N. J.
55026	Simpson Electric Co.	Chicago, Ill.	73506	Bradley Semiconductor Corp.	New Haven, Conn.	80120	Schnitzer Alloy Products Co.	Elizabeth, N. J.
55933	Sonolux Corp.	Elmsford, N. Y.	73559	Calling Electric, Inc.	Hartford, Conn.	80131	Electronic Industries Association, Any brand Tube meeting EIA Standards-Washington, DC.	Washington, DC.
55938	Raytheon Co. Commercial Apparatus & Systems Div.	So. Norwalk, Conn.	73586	Circle F Mfg. Co.	Trenton, N. J.	80207	Unimax Switch, Div. Moxon Electronics Corp.	Wallingford, Conn.
56137	Spaulding Fibre Co., Inc.	Tonawanda, N. Y.	73682	George K. Garrett Co., Div. MSL Industries Inc.	Philadelphia, Pa.	80223	United Transformer Corp.	New York, N. Y.
56289	Sprague Electric Co.	North Adams, Mass.	73743	Fischer Special Mfg. Co.	Chicago, Ill.	80248	Gaford Electric Corp.	Chicago, Ill.
59446	Telon Corp.	Tulsa, Okla.	73793	General Industries Co., The	Cincinnati, Ohio	80294	Honrus Inc.	Riverside, Calif.
59730	Thomas & Betts Co.	Elizabeth, N. J.	73816	Goshen Stamping & Tool Co.	Elyria, Ohio	80411	Acro Div. of Robertshaw Controls Co.	Columbus, Ohio
60741	Triplet Electrical Inst. Co.	Buffalo, Ohio						
61775	Union Switch and Signal, Div. of Westinghouse Air Brake Co.	Pittsburgh, Pa.						

80015-47
Revised: April, 1969

From: FSC. Handbook Supplements

TABLE 6-3.
CODE LIST OF MANUFACTURERS (Continued)

Code No.	Manufacturer	Address	Code No.	Manufacturer	Address	Code No.	Manufacturer	Address
80486	All Star Products Inc.	Delftaco, Ohio	86684	Radio Corp. of America, Electronic Comp. & Devices Div.	Harrison, N. J.	95566	Arnold Engineering Co.	Marango, Ill.
80509	Avery Label Co.	Menlo Park, Calif.	86928	Sears Roebuck & Co.	Glendale, Calif.	95712	Dage Electric Co., Inc.	Franklin, Ind.
80583	Numarfluid Co., Inc.	Warr Hill, N. C.	87034	Marco Industries	Anaheim, Calif.	95984	Siemon Mfg. Co.	Wayne, Ill.
80640	Stevens, Arnold, Co., Inc.	Boston, Mass.	87216	Philco Corporation (Lansdale Division)	Lansdale, Pa.	95987	Weckesser Co.	Chicago, Ill.
80663	Dinco Gray Co.	Dayton, Ohio	87473	Western Fibrous Glass Products Co.	San Francisco, Calif.	96067	Microwave Assoc., West Inc.	Sunnyvale, Calif.
81030	International Instruments Inc.	Oraago, Conn.	87664	Van Waters & Rogers Inc.	San Francisco, Calif.	96095	Hi-Q Div. of Aerover Corp.	Olean, N. Y.
81073	Grayhill Co.	LaGrange, Ill.	87930	Tower Mfg. Corp.	Providence, R. I.	96256	Thordarson-Melsson Inc.	Mt. Carmel, Ill.
81095	Triad Transformer Corp.	Yonca, Calif.	88140	Cutter-Hammer, Inc.	Liscola, Ill.	96296	Sofar Manufacturing Co.	Los Angeles, Calif.
81312	Winchester Elec. Div. Litton Ind., Inc.	Oakville, Conn.	88220	Gold-National Batteries, Inc.	St. Paul, Minn.	96306	Micronitch, Div. of Minn.-Honeywell	Freeport, Ill.
81349	Military Specification		88698	General Mills, Inc.	Buffalo, N. Y.	96330	Carlton Screw Co.	Chicago, Ill.
81403	International Rectifier Corp.	El Segundo, Calif.	89231	Graybar Electric Co.	Oakland, Calif.	96341	Microwave Associates, Inc.	Burlington, Mass.
81541	Airpan Electronics, Inc.	Cambridge, Maryland	89473	G. E. Distributing Corp.	Schenectady, N. Y.	96301	Excel Transformer Co.	Oakland, Calif.
81866	Barry Controls, Div. Barry Wright Corp.	Watertown, Mass.	89665	United Transformer Co.	Chicago, Ill.	96733	San Fernando Elect. Mfg. Co.	San Fernando, Calif.
82042	Cartor Precision Electric Co.	Shakio, Ill.	90030	United Shoe Machinery Corp.	Beverly, Mass.	96881	Thomson Ind. Inc.	Long Is., N. Y.
82047	Sports Faraday Inc., Copper Hewitt Electric Div.	Hoboken, N. J.	90129	US Rubber Co., Consumer Ind. & Plastic Prod. Div.	Passaic, N. J.	97464	Industrial Retaining Ring Co.	Irrington, N. J.
82116	Electric Regulator Corp.	Normal, Conn.	90970	Bearing Engineering Co.	San Francisco, Calif.	97539	Automatic & Precision Mfg.	Englewood, N. J.
82142	Jelfers Electronics Division of Sparr Carbon Co.	De Bolo, Pa.	91146	ITT Cannon Elect. Inc., Salem Div.	Salem, Mass.	97979	Reco Adjuster Corp.	Yonkers, N. Y.
82170	Fairchild Camera & Inst. Corp. Space & Defense System Div.	Paramus, N. J.	91260	Coonor Spring Mfg. Co.	San Francisco, Calif.	97983	Litton System Inc., Adler-Westrox Commun. Div.	New Rochelle, N. Y.
82209	Maguire Industries, Inc.	Canaan, Conn.	91345	Miller Dial & Nameplate Co.	El Monte, Calif.	98141	R-Tronic, Inc.	Jamaica, N. Y.
82219	Sylvania Electric Prod. Inc. Electronic Tube Division	Emporium, Pa.	91418	Radio Materials Co.	Chicago, Ill.	98159	Rubber Tech, Inc.	Gardena, Calif.
82376	Astron Corp.	East Newark, N. J.	91506	Augat Inc.	Attleboro, Mass.	98220	Hewlett-Packard Co., Moseley Div.	Pasadena, Calif.
82389	Switchcraft, Inc.	Chicago, Ill.	91637	Dale Electronics, Inc.	Columbus, Mebr.	98270	Micradol, Inc.	So. Pasadena, Calif.
82547	Metals & Controls Inc. Spencer Products	Attleboro, Mass.	91662	Eico Corp.	Willow Grove, Pa.	98291	Seallecto Corp.	Mamaroneck, N. Y.
82760	Phillips-Advance Control Co.	Joliet, Ill.	91737	Gromer Mfg. Co., Inc.	Wohlfeld, Mass.	98376	Zero Mfg. Co.	Burbank, Calif.
82866	Research Products Corp.	Madison, Wis.	91827	K F Development Co.	Redwood City, Calif.	98410	Etc. Inc.	Cleveland, Ohio
82877	Rotron Mfg. Co., Inc.	Woodstock, N. Y.	91846	Nalco Mfg. Co., Inc.	Chicago, Ill.	98731	General Mills Inc., Electronics Div.	Minneapolis, Minn.
82893	Vector Electronic Co.	Glendale, Calif.	91929	Honeywell Inc., Micro Switch Div.	Freeport, Ill.	98734	Pasco Div. of Hewlett-Packard Co.	Palo Alto, Calif.
83014	Marshall Corp.	Los Angeles, Calif.	91961	Nahn-Bros. Spring Co.	Oakland, Calif.	98821	North Hills Electronics, Inc.	Palo Alto, Calif.
83050	Carr Fastener Co.	Cambridge, Mass.	92180	Tru-Connector Corp.	Peabody, Mass.	98978	International Electronic Research Corp.	Glenn Cove, N. Y.
83086	New Hampshire Ball Bearing, Inc.	Peterborough, N. H.	92607	Tessalite Insulated Wire Co., Inc.	Rockster, N. Y.	99109	Columbia Technical Corp.	Burbank, Calif.
83125	General Instrument Corp., Capacitor Div.	Darlington, S. C.	92702	IMC Magnetics Corp.	Tarrytown, N. Y.	99313	Varian Associates	New York, N. Y.
83148	ITT Wire and Cable Div.	Los Angeles, Calif.	92966	Hudson Lamp Co.	Westbury Long Island, N. Y.	99379	Altee Corp.	Palo Alto, Calif.
83186	Victory Eng. Corp.	Springfield, N. J.	93332	Sylvania Electric Prod. Inc. Semiconductor Div.	Woburn, Mass.	99515	Marshall Ind., Capacitor Div.	Winchester, Mass.
83238	Bendix Corp., Red Wash Div.	Irving Park, N. J.	93369	Robbins & Myers Inc.	Palladium Park, N. J.	99570	Control Switch Division, Controls Co. of America	El Segundo, Calif.
83315	Hubbell Corp.	Hondolola, Ill.	93410	Stanco Controls, Div. of Essex Wire Corp.	Mansfield, Ohio	99800	Duovan Electronics Corp.	East Aurora, N. Y.
83324	Rossan Inc.	Newport Beach, Calif.	93632	Waters Mfg. Co.	Culver City, Calif.	99848	Wilco Corporation	Indianapolis, Ind.
83330	Smith, Norman H., Inc.	Brooklyn, N. Y.	93929	G. V. Controls	Livingston, N. J.	99928	Branson Corp.	Whippany, N. J.
83332	Tech Labs	Palaada's Park, N. J.	94137	General Cable Corp.	Bayonne, N. J.	99934	Reubrandt, Inc.	Boston, Mass.
83385	Central Screw Co.	Chicago, Ill.	94142	Phelps Dodge	Yonkers, N. Y.	99942	Hoffman Electronics Corp. Semiconductor Div.	El Monte, Calif.
83501	Gavitt Wire and Cable Co. Div. of Amerace Corp.	Brookfield, Mass.	94144	Raytheon Co., Comp. Div., Ind. Comp. Operations	Quincy, Mass.	99957	Technology Instrument Corp. of Calif.	Hemlock Park, Calif.
83594	Barroughs Corp. Electronic Tube Div.	Plainfield, N. J.	94148	Scientific Electronics Products, Inc.	Loveland, Colo.			
83740	Union Carbide Corp. Consumer Prod. Div.	New York, N. Y.	94154	Wagner Elect. Corp., Tang-Sai Div.	Newark, N. J.			
83777	Model Eng. and Mfg., Inc.	Huntington, Ind.	94197	Carliss-Wright Corp. Electronics Div.	East Paterson, N. J.			
83821	Loyd Scruggs Co.	Fenton, Mo.	94222	South Chester Corp.	Chester, Pa.			
83942	Aeronautical Inst. & Radio Co.	Lodi, N. J.	94330	Wire Cloth Products, Inc.	Belwood, Ill.			
84171	Arco Electronics Inc.	Great Neck, N. Y.	94375	Automatic Metal Products Co.	Brooklyn, N. Y.			
84396	A. J. Giesener Co., Inc.	San Francisco, Calif.	94482	Worcester Pressed Aluminum Corp.	Worcester, Mass.			
84411	TRW Capacitor Div.	Ogallala, Neb.	94696	Magnecraft Electric Co.	Chicago, Ill.			
84970	Sarkon Textile, Inc.	Bloomington, Ind.	95023	George A. Philbrick Researchers, Inc.	Boston, Mass.			
85454	Bonaton Welding Company	Boonlan, N. J.	95236	Allies Products Corp.	Dania, Fla.			
85471	A. B. Boyd Co.	San Francisco, Calif.	95238	Continental Connector Corp.	Woodside, N. Y.			
85474	R. W. Bracconia & Co.	San Francisco, Calif.	95263	Luercraft Mfg. Co., Inc.	Long Island, N. Y.			
85468	Kelley Kords, Inc.	Hendon, Conn.	95265	National Coil Co.	Sherridan, Wyo.			
85811	Seamless Rubber Co.	Chicago, Ill.	95275	Vitramon, Inc.	Bridgeport, Conn.			
86174	Fairair Bearing Co.	Los Angeles, Calif.	95348	Gordon Corp.	Bloomfield, N. J.			
86197	Clifton Precision Products Co., Inc.	Clifton Heights, Pa.	95354	Hethode Mfg. Co.	Rolling Meadows, Ill.			
86379	Precision Rubber Products Corp.	Dayton, Ohio						

THE FOLLOWING NP VENDORS HAVE NO NUMBER ASSIGNED IN THE LATEST SUPPLEMENT TO THE FEDERAL SUPPLY CODE FOR MANUFACTURERS HANDBOOK.

0000F	Malco Tool and Die	Los Angeles, Calif.
0000Z	Willow Leather Products Corp.	Newark, N. J.
000AB	ETA	England
000BB	Precision Instrument Components Co.	Van Nuys, Calif.
000CS	Hewlett-Packard Co., Colorado Springs	Colorado Springs, Colorado
000NN	Rubber Eng. & Development	Hayward, Calif.
000NN	A "M" O Mfg. Co.	San Jose, Calif.
000QQ	Coeltra	Oakland, Calif.
000WW	California Eastern Lab.	Burlington, Calif.
000YY	S. K. Smith Co.	Los Angeles, Calif.

SECTION VII SCHEMATIC DIAGRAMS

7-1. INTRODUCTION.

7-2. Schematic presentations in this manual show electrical circuit operation and are not intended to serve as wiring diagrams. Figure 7-1 lists notes which apply to the schematic diagrams.

7-3. Some switch and circuit board assemblies are shown in part on different pages. To find a specific instrument component, refer to the "REFERENCE DESIGNATIONS" box which appears on each schematic diagram. Reference designations within assemblies are abbreviated. The full designation includes the assembly on which the component is mounted, and the individual component designation. For example, Resistor R1 mounted on Assembly A1 has the complete reference designation of A1R1. Certain parts are not included on assemblies, and are classified as chassis parts. Chassis parts are assigned only the reference designation shown on the schematic diagram.

7-4. This section also contains information on component and test point locations within the instrument. Figure 7-4 shows the Power Meter Assembly, A1, and

Figure 7-6 shows the Power Supply Assembly, A2. Figure 7-2 shows switch component locations.

7-5. Figures 7-3 and 7-8 illustrate normal-operation waveforms obtained at test points 1 through 6. Normal-operation voltages are given on the schematic diagrams, adjacent to the point of measurement. All voltages and waveforms were taken with the instrument zeroed and nulled and a 200 ohm thermistor mount connected in accordance with Figure 3-8, Turn-On and Nulling Procedure. Full scale voltage measurements were made by setting the meter to full scale deflection with the ZERO control.

7-6. An asterisk indicates a factory selected part; the component value shown is the typical or most commonly selected value. Circuit requirements that determine the values of factory selected parts are listed in Table 5-3.

7-7. Component procurement information and specific component descriptions are included in Section VI. Refer to page 6-1 for information on how to order parts.

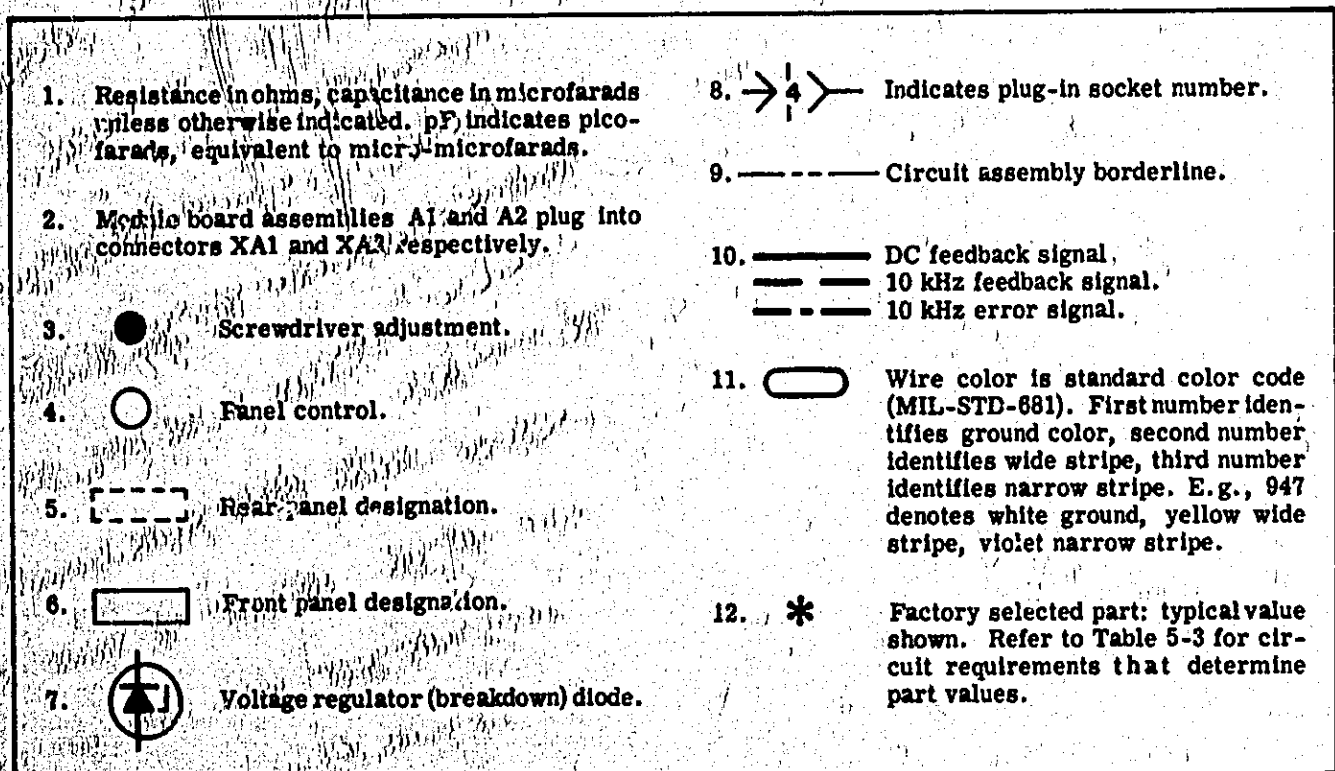
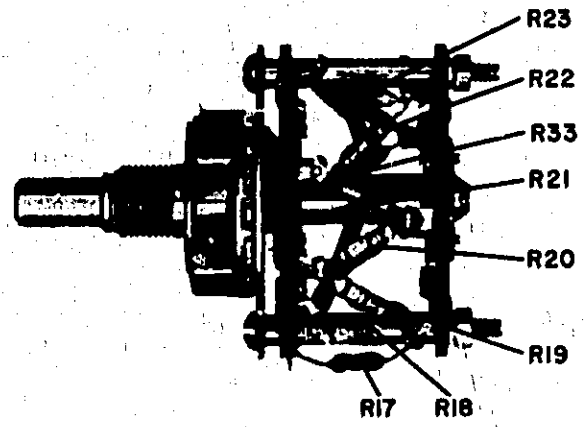
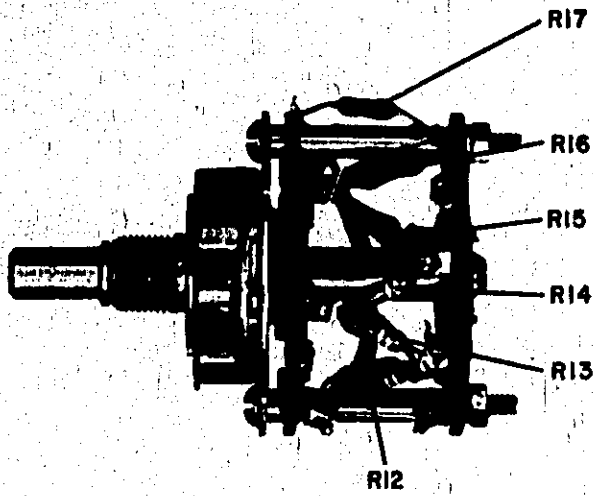
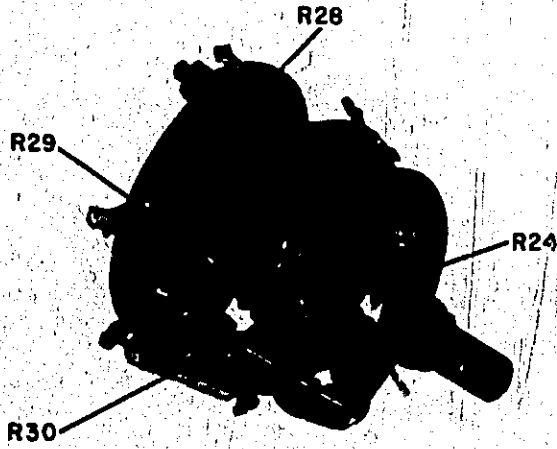

Figure 7-1. Schematic Diagram Notes



S4
CALIB. FACTOR
SWITCH

431C-A-18



S3
POWER SWITCH

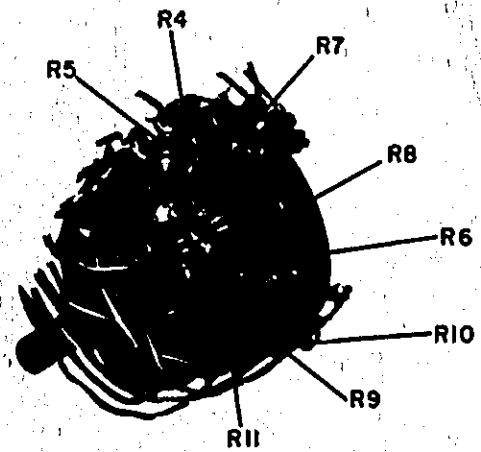

S2
RANGE SWITCH

Figure 7-2. Switch Component Locations

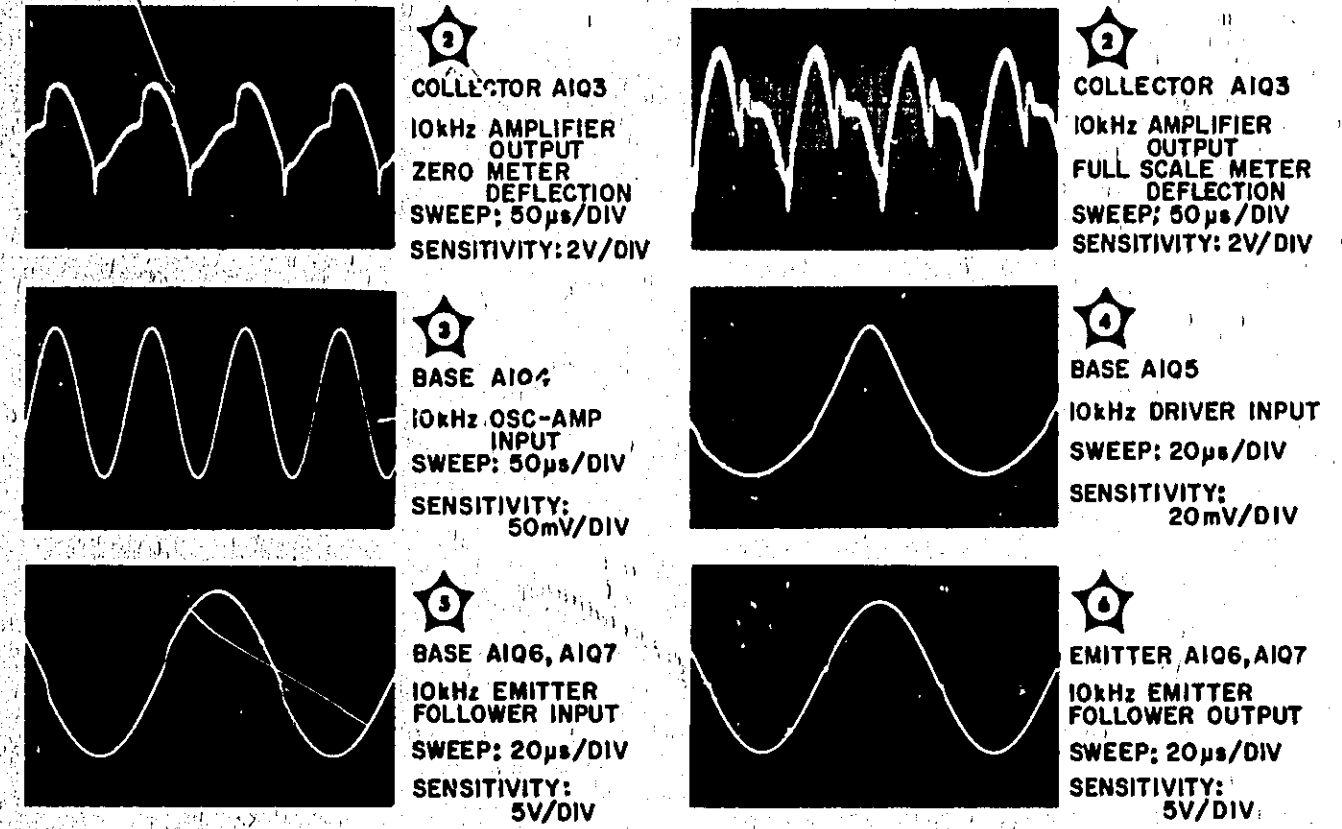

Figure 7-3. Assembly A1 Waveforms

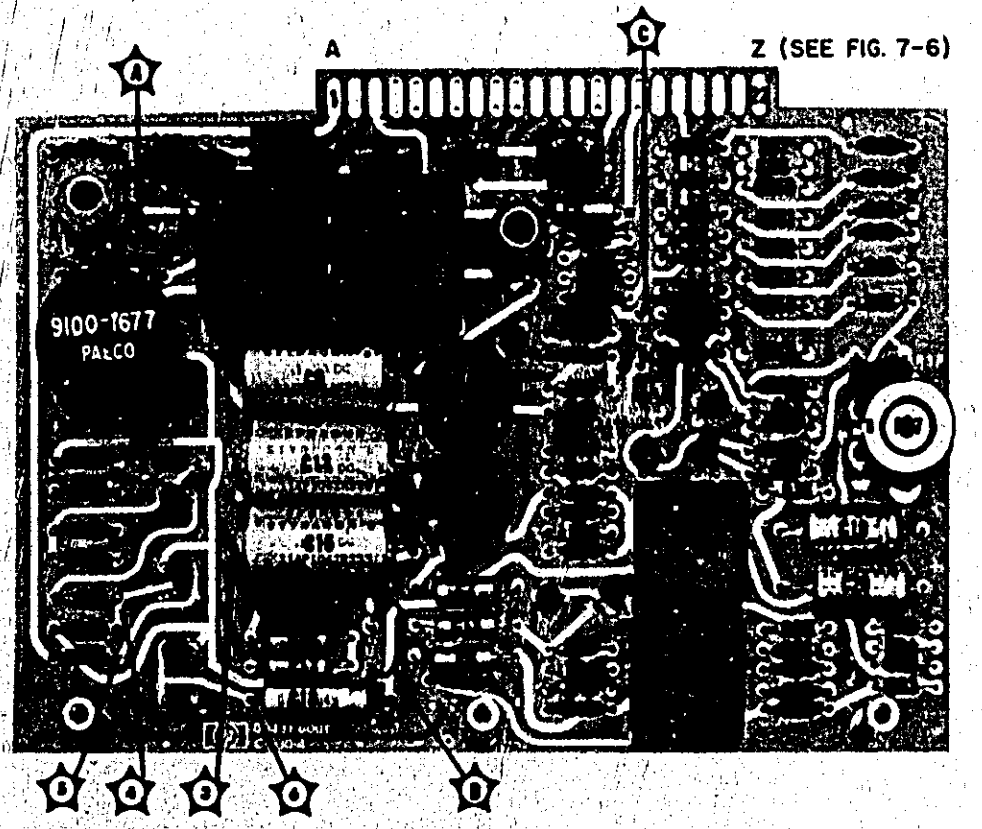
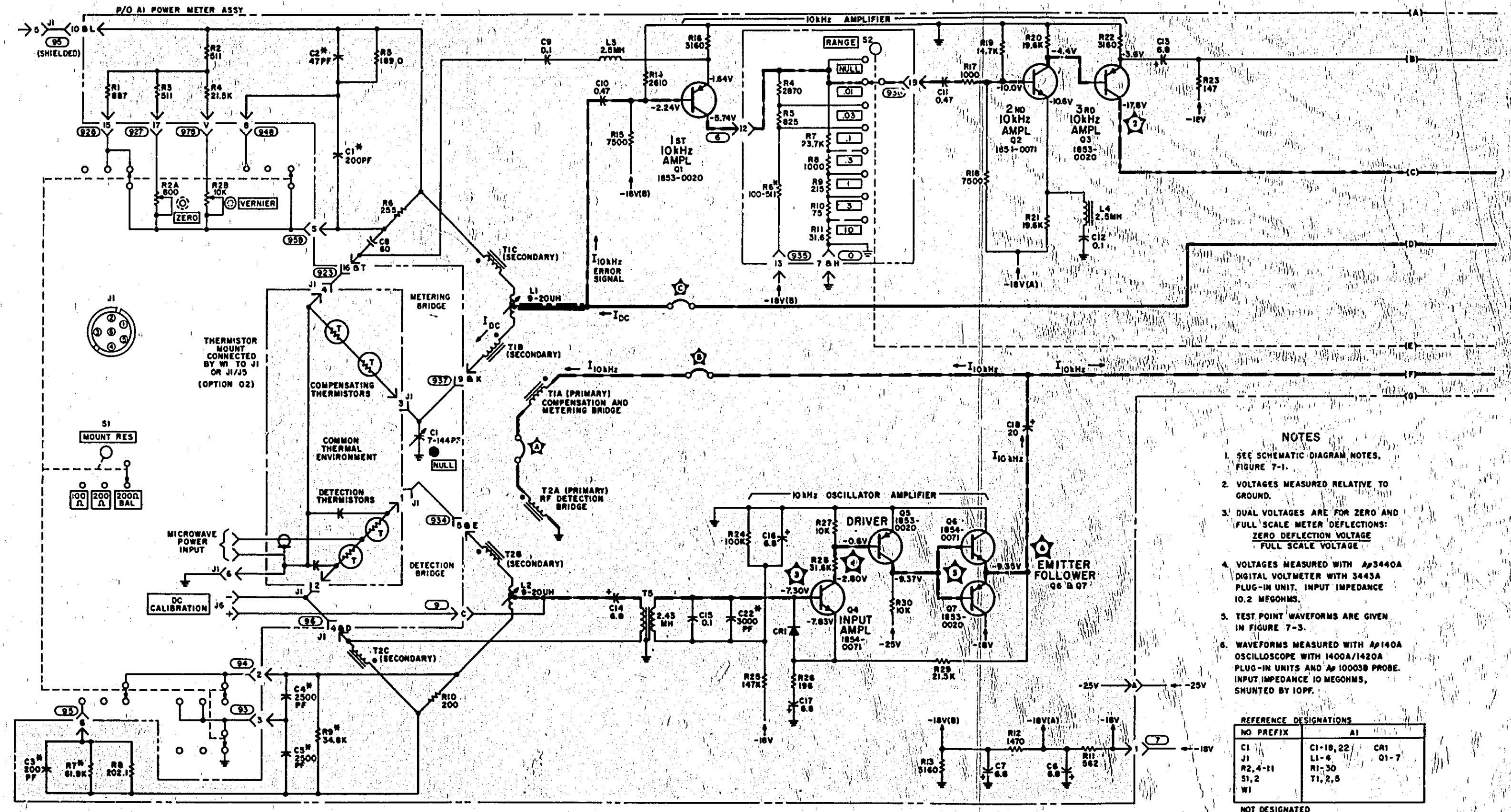
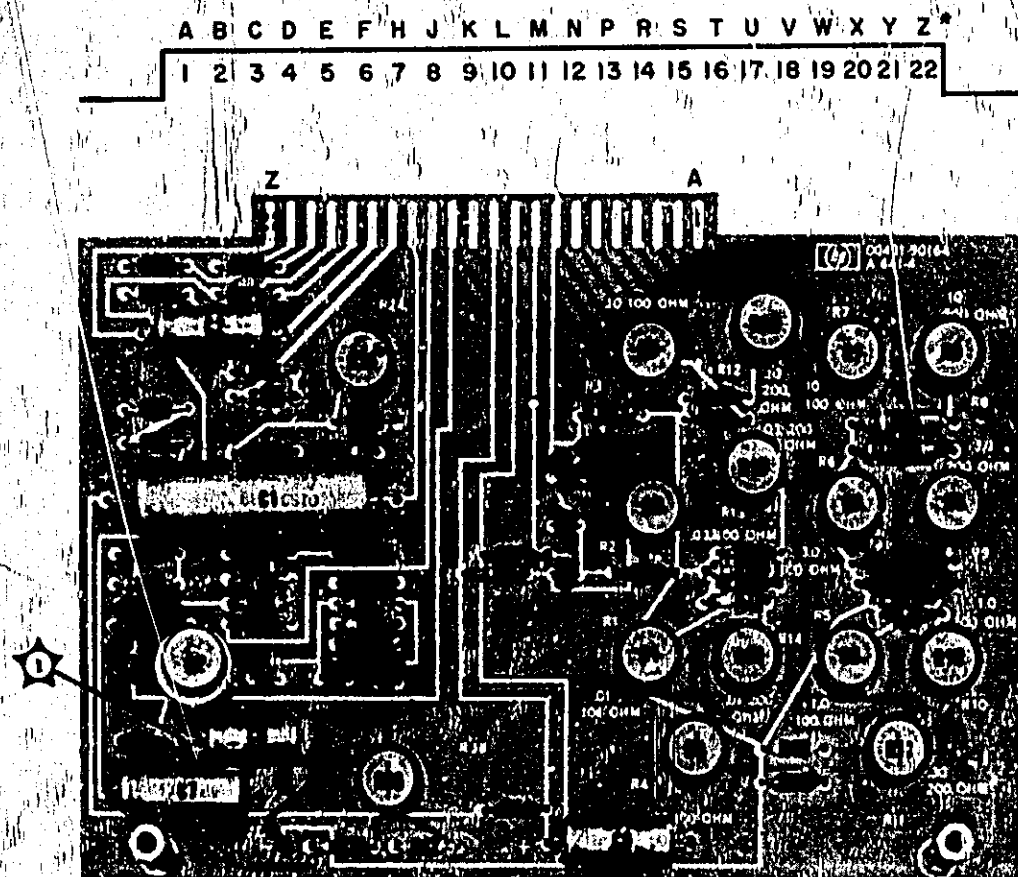

Figure 7-4. Power Meter Assembly A1



- NOTES**
- SEE SCHEMATIC DIAGRAM NOTES, FIGURE 7-1.
 - VOLTAGES MEASURED RELATIVE TO GROUND.
 - DUAL VOLTAGES ARE FOR ZERO AND FULL SCALE METER DEFLECTIONS:
ZERO DEFLECTION VOLTAGE
FULL SCALE VOLTAGE
 - VOLTAGES MEASURED WITH AP3440A DIGITAL VOLTMETER WITH 3443A PLUG-IN UNIT. INPUT IMPEDANCE 10.2 MEGOHMS.
 - TEST POINT WAVEFORMS ARE GIVEN IN FIGURE 7-3.
 - WAVEFORMS MEASURED WITH AP140A OSCILLOSCOPE WITH 1400A/1420A PLUG-IN UNITS AND AP10003B PROBE. INPUT IMPEDANCE 10 MEGOHMS, SHUNTED BY 10PF.
- | REFERENCE DESIGNATIONS | | |
|------------------------|-----------|------|
| NO PREFIX | A1 | |
| C1 | C1-18, 22 | CR1 |
| J1 | L1-4 | Q1-7 |
| R2, 4-11 | R1-30 | |
| S1, 2 | T1, 2, 5 | |
| W1 | | |
| NOT DESIGNATED | | |
| R1, 3, 31, 32 | | |
| A2R23 | | |

Figure 7-5. Detection and Metering Bridges with 10 kHz Oscillator Amplifier and 10 kHz Amplifier



*(LETTER DESIGNATIONS REFER TO PINS ON REVERSE SIDE OF BOARD)

Figure 7-6. Power Supply Assembly A2

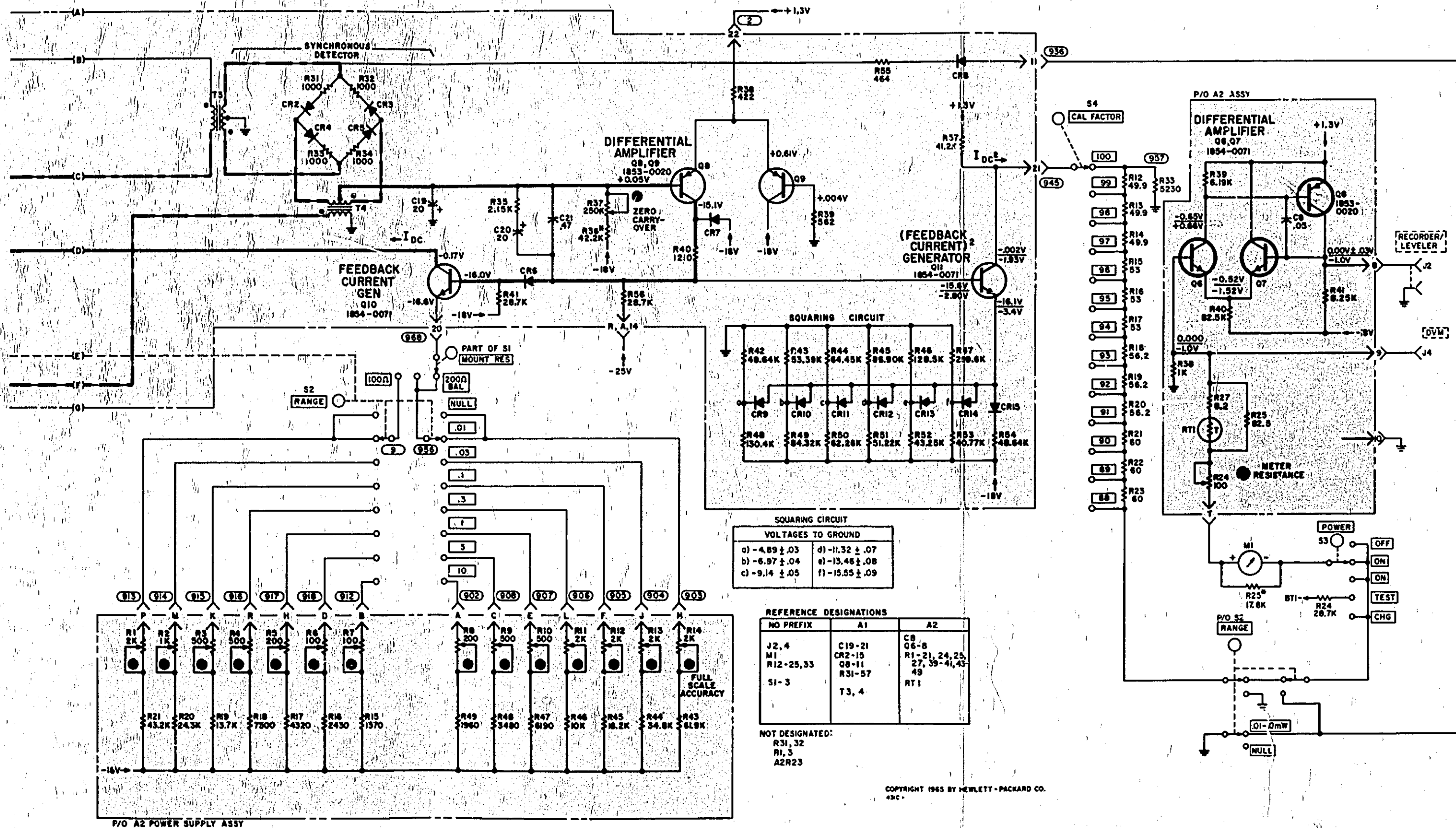
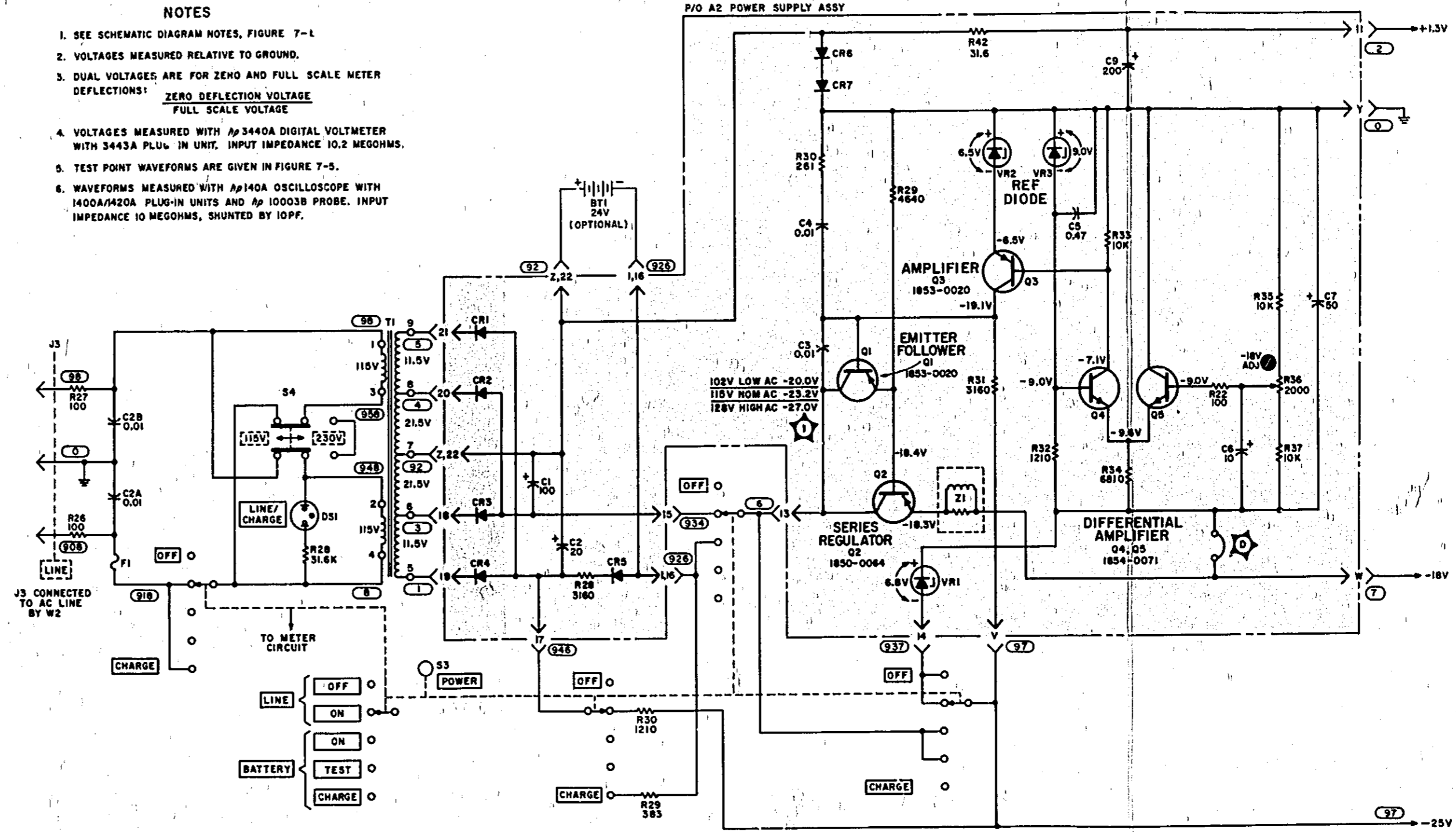

Figure 7-7. Synchronous Detector, Feedback and Metering Circuits



1
COLLECTOR A2Q1,A2Q2
REGULATOR INPUT
SWEEP: 5ms/DIV
SENSITIVITY: 0.5V/DIV

Figure 7-8. Power Supply Waveform



COPYRIGHT 1965 BY HEWLETT-PACKARD CO.
91C-PWS SUP

Figure 7-9. Power Supply

APPENDIX I

OPTION 01

A1-1. The 431C Option 01 instrument consists of a standard Model 431C Power Meter with a rechargeable battery installed. A list of Option 01 component parts is given in Table 6-1. Instruction for installation of the battery is given in the following paragraph.

A1-2. OPTION 01 INSTALLATION PROCEDURE.

- a. Set POWER switch to LINE OFF and remove power plug from power meter.
- b. Remove top and bottom instrument covers.
- c. Refer to Figure A1-1 which shows the battery cover disassembled from the battery. Install the battery and battery cover from the bottom of the instrument into the top chassis. Note that the battery is installed so that the two battery terminals are toward the top and front of the instrument.
- d. Secure the battery in place with four retaining nuts.

CAUTION

Be careful not to short the battery terminals; battery cell damage may result.

- e. Solder a red wire (No. 22 gauge, stranded) between the positive battery terminal and circuit board connector XA2, pin Z.
- f. Solder a black wire (No. 22 gauge, stranded) between the negative battery terminal and circuit board connector XA2, pin 1.

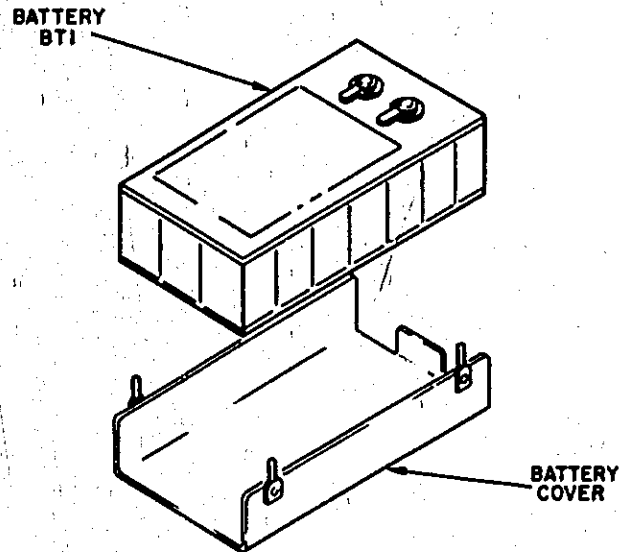

Figure A1-1. Battery and Battery Cover Assembly

OPTION 02

A1-3. Option 02 consists of a standard panel mount cable connector which is installed on the rear panel of the meter in the place provided. Wiring is included. The front and rear panel cable connectors are connected parallel, but can not be operated simultaneously.

Kit stock No. 00431-6102

Includes:

Wiring harness and connector .. 00431-6012

Nut, Knurled..... 1251-1281

Color codes remain the same for all wiring. Wires are connected in parallel with the front panel connector at XA1 and XA2.

APPENDIX II INSTALLATION OF LONG CABLE OPTIONS

A2-1. INTRODUCTION

A2-2. Information in this appendix describes installation of long cable options used with the 431C Power Meter. Table A2-1 lists cable lengths, stock numbers, and mount resistances by option number. Values of components supplied with the long cable options are nominal. Installation procedures adjust the Power Meter 10 kHz bias oscillator frequency, reset the bridge null balance, and reset the bridge resistances for optimum operation. At the completion of the installation procedure, the Power Meter should be recalibrated using the procedures outlined in Section V.

A2-3. Depending on the option selected, the following components are replaced with parts supplied with the option kit:

a. A1C3, A1C4, A1C5, A1C23*.

b. A1R7, A1R9.

Prior to beginning the regular installation procedure, remove the following components:

a. A1C4, A1C5.

b. A1R7, A1R9.

During installation the following equipment will be required:

HP 8402B Power Meter Calibrator

HP 175A or 140A Oscilloscope

HP 410B/C or 412A or 427A Ohmmeter

HP 5512A Electronic Counter

Table A2-1. 431C Power Meter Long Cable Options

Option	Kit Stock Number	Cable Length (Feet)	Thermistor Mount Resistance
09	00431-6109	10	100 or 200 (Bal or Unbal)
10	00431-6110	20	100 or 200 (Bal or Unbal)
11	00431-6111	50	100
12	00431-6112	100	100
13	00431-6113	200	100
21	00431-6121	50	200 Unbalanced
22	00431-6122	100	200 Unbalanced
23	00431-6123	200	200 Unbalanced
24	00431-6124	200	200 Balanced

*(A1C23 is installed between A1 pin 9 and A1 pin 7 for Option 13 only.)

A2-4. OSCILLATOR FREQUENCY ADJUSTMENT.

A2-5. Connect the frequency counter from A1C18 (+) to ground to measure the output of the 10 kHz bias oscillator. Use the applicable procedures below according to the option selected. Install cable and mount, and turn 431C MOUNT RES switch to proper value.

NOTE

Supplied values of A1C4 and A1C5 (2000-2500 pF) are nominal. Values must be within $\pm 1\%$ of each other.

A1C3 should not exceed 1000 pF.

a. Options 09, 10 (100 Ohm Mounts):

1. Center A1L2.
2. Install supplied values for A1C4 and A1C5.
3. Select and install A1C3 so that the oscillator frequency is 10 kHz ± 0.05 kHz.
4. Do not adjust A1L2.

b. Options 09, 10 (200 Ohm Mounts):

1. Center A1L2.
2. Select and install values for A1C4 and A1C5 to produce an oscillator output frequency of 10 kHz ± 0.1 kHz.
3. Do not adjust A1L2.

c. Options 09, 10 (200 Ohm Balanced Mounts):

1. Center A1L2.
2. Select and install values for A1C4 and A1C5 to produce an oscillator output frequency of 10 kHz ± 0.01 kHz.
3. Do not adjust A1L2.

d. Options 11, 12, 13 (100 Ohm Mounts):

1. Center A1L2
2. Install supplied values for A1C4 and A1C5
3. Install supplied value for A1C3
4. Adjust A1L2 for an oscillator frequency of 10 kHz ± 0.05 kHz.

e. Options 21, 22, 23 (200 Ohm Unbalanced Mounts):

1. Center A1L2
2. Install supplied values for A1C4 and A1C5
3. Adjust A1L2 for an oscillator frequency of 10 kHz ± 0.1 kHz.

f. Option 24 (200 Ohm Balanced Mounts):

1. Center A1L2
2. Install supplied values for A1C4 and A1C5
3. Adjust A1L2 for an oscillator frequency of 10 kHz \pm 0.01 kHz.

A2-6. COARSE NULL ADJUSTMENTS.

A2-7. Options 09, 10, 11, 12, 13 (100 Ohm Thermistor Mount):

- a. Connect 100 ohm thermistor mount to power meter.
- b. Connect oscilloscope to junction of A1R55 and A1CR8.
- c. Set power meter control as follows:

POWER ON
 RANGE 01 mW
 CALIB FACTOR 100%
 MOUNT RES 100 Ohm

d. Adjust ZERO control for an on-scale meter reading.

e. Mechanically center Null capacitor, C1.

NOTE

For OPTION 13, install A1C23 between A1 pin 9 and A1 pin 7. Nominal value: 1600 pF. Pad if necessary to obtain null in step f.

f. Adjust A1L1 for a voltage null at A1R55. Adjust NULL capacitor C1 for a zero power meter reading. C1 should remain near mechanical center \pm 10°.

g. Set power meter RANGE switch to NULL, and adjust NULL capacitor C1 for a zero power meter reading. C1 should remain near mechanical center \pm 10°.

h. Rotate power meter RANGE switch clockwise through remaining ranges. Voltage null at A1R55 should remain less than 1.5 volts peak-to-peak.

A2-8. Options 09, 10, 21, 22, 23, 24 (200 Ohm Thermistor Mount):

- a. Connect 200 ohm thermistor mount to power meter.
- b. Connect oscilloscope or AC voltmeter from A1R55 to ground.
- c. Set power meter controls as follows:

POWER ON
 RANGE 01 mW
 CALIB FACTOR 100%
 MOUNT RES 200 Ohm

d. Adjust ZERO control for an on-scale meter reading.

A2-2

e. Mechanically center NULL capacitor C1.

f. Select capacitor A1C1 for a voltage null at A1R55. Fine adjust NULL capacitor C1 for less than 1.5 volts peak-to-peak.

g. Set power meter RANGE switch to NULL, and fine adjust NULL capacitor C1 for a zero power meter reading. C1 should remain near mechanical center \pm 45°.

NOTE

If a null cannot be obtained, do not select A1C1 for a value greater than 1000 pF. Increase A1C2 in 50 pF steps, and repeat procedure.

A2-9. Bridge Resistance Adjustment:

a. Connect the 431C Thermistor cable to the 8402B RESISTANCE STANDARD connector.

b. Set the 8402B Mount Resistance to the proper setting for the mount used and the 8402B THERMISTOR RESISTANCE to 0.

1. Options 09, 10, 11, 12 (100 Ohm):

Connect the following circuit in place of A1R7.

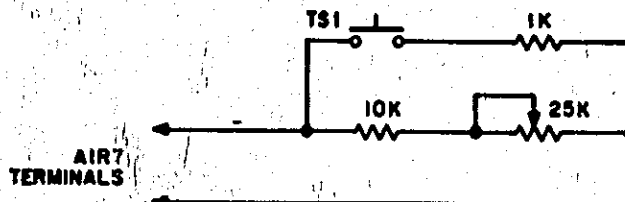

Figure A2-1. Test Network for 100 Ohm Calibration

2. Observe the 10kHz oscillator output at A1C18 (+) with an oscilloscope.

3. Press TS1 periodically while increasing resistance of the 25K pot. When oscillations cease, measure the total resistance of the network. Find the closest value in the chart below and install the next lowest value in place of A1R7.

100 Ohm Resistance Selection Chart

1. 10K
2. 11K
3. 12.1K
4. 13.3K
5. 14.7K
6. 16.2K
7. 17.8K
8. 19.6K
9. 21.5K
10. 23.7K
11. 26.1K
12. 28.7K

4. Recalibrate the 431C using the procedures in Section V.
- c. Options 09, 10, 21, 22, 23, 24 (200 Ohm and 200 Ohm Balance):
 1. Observe the 10 kHz oscillator output at A1C18 A1R10 (lugs provided on board).

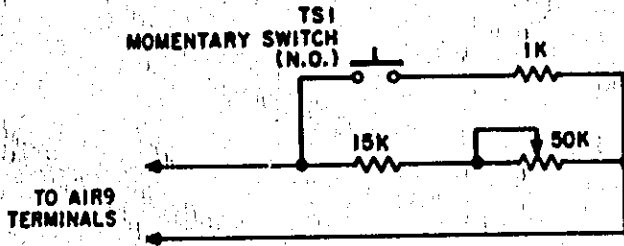

Figure A2-2. Test Network for 200 Ohm Calibration

3. Set the 50K pot to minimum resistance and press TS1 periodically. The oscilloscope display is the oscillator output; slowly increase resistance until oscillation stops.
4. Disconnect The resistance network and measure its total resistance. Take the value from the table below closest to the measured resistance, move back to the next lowest value and install a 1/8 watt meter film resistor of this value on the A1 board in the place provided for A1R9.

200 Ohm and 200 Ohm Balance

Resistance Selection Chart

1. 19.6K
2. 21.5K
3. 23.7K
4. 26.1K
5. 28.7K
6. 31.6K
7. 34.8K
8. 38.3K
9. 42.2K
10. 46.4K
11. 51.1K
12. 56.2K

5. Switch the 8402B THERMISTOR RESISTANCE between -.1, 0 and +.1%. The 431C meter shall read 0 and on-scale respectively, with THERMISTOR RESISTANCE settings of -.1% and 0, or 0 and +.1%, indicating that the bridge resistance error is less than ±.1%.

6. Recalibrate the 431C using the procedures in Section V.

Table A2-2. Converter Kit Parts List

<u>OPTION 09 (100/200Ω)</u>		<u>HP Part No.</u>	<u>OPTION 11 (50 ft) (100Ω) (Continued)</u>		<u>HP Part No.</u>
<u>Quantity</u>	<u>Description</u>		<u>Quantity</u>	<u>Description</u>	
1	Nameplate, identification	00431-0009	1	Resistor, fixed 208.8Ω for R8	0811-2090
1	Cable, 10 ft	8120-1083	1	Nameplate, identification	00431-0011
<u>OPTION 10 (20 ft) (100Ω or 200Ω)</u>		00431-6110	1	Cable, 50 ft	8120-1085
2	Capacitor, 2500 pF for C4, 5	0160-0147	<u>OPTION 12 (100 ft) (100Ω)</u>		00431-6112
1	Resistor, fixed 200.7Ω for R10	0811-2087	1	Capacitor, fixed 1100 pF for C5	0160-2219
1	Resistor, fixed 204.6Ω for R8	0811-2088	1	Resistor, fixed 323Ω for R1	0698-5662
1	Nameplate, identification	00431-0010	1	Resistor, fixed 195.5Ω for R5	0811-2086
1	Cable, 20 ft	8120-1084	1	Resistor, fixed 204.6Ω for R10	0811-2088
<u>OPTION 11 (50 ft) (100Ω)</u>		00431-6111	1	Resistor, fixed 216.0Ω for R8	0811-2091
2	Capacitor, fixed 2700 pF for C4, 5	0160-2228	1	Resistor, fixed 259.4Ω for R6	0811-2093
1	Resistor, fixed 202.1Ω for R10	0811-1645	1	Nameplate, identification	00431-0012
1	Resistor, fixed 189.8Ω for R5	0811-2085	1	Cable, 100 ft	8120-1086

Table A2-2. Conversion Kit Parts List (Cont.)

<u>OPTION 13 (200 ft) (100Ω)</u>		<u>HP Part No.</u>	<u>OPTION 22 (100 ft) (200Ω) (Continued)</u>		<u>HP Part No.</u>
<u>Quantity</u>	<u>Description</u>		<u>Quantity</u>	<u>Description</u>	
1	Capacitor, fixed 910 pF for C5	0160-2217	1	Resistor, fixed 259.4 Ω for R6	0811-2093
1	Capacitor, fixed 1800 pF for C23	0160-2223	1	Nameplate, identification	00431-0022
1	Resistor, fixed 330 Ω for R1	0698-5663	1	Cable, 100 ft	8120-1086
1	Resistor, fixed 207.1 Ω for R5	0811-2089	<u>OPTION 23 (200 ft) (200Ω)</u>		00431-6123
1	Resistor, fixed 208.8 Ω for R10	0811-2090	1	Capacitor, fixed 4300 pF for C5	0160-2036
1	Resistor, fixed 231.4 Ω for R8	0811-2092	1	Resistor, fixed 330 Ω for R1	0698-5663
1	Resistor, fixed 265.2 Ω for R6	0811-2094	1	Resistor, fixed 207.1 Ω for R5	0811-2089
1	Nameplate, identification	00431-0013	1	Resistor, fixed 208.8 Ω for R10	0811-2090
1	Cable, 200 ft	8120-1087	1	Resistor, fixed 231.4 Ω for R8	0811-2092
<u>OPTION 21 (50 ft) (200Ω)</u>		000431-6121	1	Resistor, fixed 265.2 Ω for R6	0811-2094
2	Capacitor, fixed 2700 pF for C4, 5	0160-2228	1	Nameplate, identification	00431-0023
1	Resistor, fixed 202.1 Ω for R10	0811-1645	1	Cable, 200 ft	8120-1087
1	Resistor, fixed 189.8 Ω for R5	0811-2085	<u>OPTION 24 (200 ft) 200 BALANCED MOUNT ONLY</u>		00431-6124
1	Resistor, fixed 208.8 Ω for R8	0811-2090	2	Capacitor, fixed 3300 pF for C4, 5	0160-2230
1	Nameplate, identification	00431-0021	1	Resistor, fixed 330 Ω for R1	0698-5663
1	Cable, 50 ft	8120-1085	1	Resistor, fixed 207.1 Ω for R5	0811-2089
<u>OPTION 22 (100 ft) (200Ω)</u>		00431-6122	1	Resistor, fixed 208.8 Ω for R10	0811-2090
2	Capacitor, fixed 3300 pF for C4, 5	0160-2230	1	Resistor, fixed 231.4 Ω for R8	0811-2092
1	Resistor, fixed 323.0 Ω for R1	0698-5662	1	Resistor, fixed 265.2 Ω for R6	0811-2094
1	Resistor, fixed 195.5 Ω for R5	0811-2086	1	Nameplate, identification	00431-0024
1	Resistor, fixed 204.6 Ω for R10	0811-2088	1	Cable, 200 ft	8120-1087
1	Resistor, fixed 216.0 Ω for R8	0811-2091			